

Power supplies and transformers

Phaseo

Creator of energy from 0.3 to 40 A

Catalogue
January

04



Selection guide pages 2 and 3

Power supplies for d.c control circuits

- Phaseo modular regulated power supplies:
 - Presentation page 4
 - Characteristics pages 5 and 6
 - Characteristics, selection page 6
 - References, dimensions, scheme page 7
- Phaseo regulated switch mode power supplies:
 - Presentation pages 8 and 9
 - Selection pages 10 and 11
 - Characteristics pages 12 to 15
 - Selection of protection page 16
 - References page 17
 - Dimensions page 18
 - Schemes page 19
- Phaseo regulated switch mode power supplies for AS-Interface:
 - Presentation page 20
 - Characteristics pages 21 and 22
 - Characteristics, selection page 22
 - References, dimensions, schemes page 23





Selection guide pages 24 and 25

Power supplies and transformers for control circuits

- Filtered rectified power supplies for d.c control circuits:
 - Presentation page 26
 - Selection page 27
 - Characteristics pages 28 and 29
 - Selection of protection page 30
 - References page 31
 - Dimensions page 32
 - Schemes page 33
- Safety and isolation transformers (25 to 2500 VA):
 - Presentation page 34
 - Selection page 35
 - Characteristics page 36
 - Selection of protection page 37
 - References page 38
 - Dimensions, schemes page 39

Schneider Electric worldwide

- Addresses pages 40 to 45

Functions	Supplies for d.c. control circuits				
Type of product	Single-phase, modular switch mode power supplies		Single-phase, regulated switch mode power supplies		
					
Applications	Industrial, commercial or residential applications. Modular format allowing integration into panels.		Simple, low power equipment.	Industrial applications, low and medium power. Machine equipment applications.	Industrial or commercial applications on sites sensitive to mains interference. Protection against accidental restarting.
Nominal power	22 W	30 W	7 W...30 W	48...240 W	60...240 W
Input voltage	~ 100...240 V single-phase		~ 100...240 V single-phase --- 110...220 V compatible (1)	~ 100...240 V single-phase	~ 100...240 V single-phase, --- 110...220 V compatible (1)
Output voltage	--- 12 V adjustable	--- 24 V adjustable	--- 24 V adjustable	--- 24 V adjustable	--- 12, 24 V or 48 V adjustable
Technology	Primary switch mode electronic power supplies.				
Secondary protection	Integrated, against overloads and short-circuits, with automatic reset.			Integrated, against overloads and short-circuits, with manual and automatic reset.	
Signalling	Output indicator lamp.			Output and input indicator lamp.	
Other characteristics	-		Connection by lug-clamps possible	-	Anti-harmonic distortion filter
Mounting	Direct on  rail		Direct, on  rail and on panel	Direct on  rail	
Disturbance (conforming to EN55011/22) Conducted and radiated	cl.B		cl.A (7/15 W) cl.B (30 W)	cl.B	
Conforming to standards	EN 50081-1, IEC 61000-6-2 (EN 50082-2), IEC 950, EN61131-2/A11		EN 50081-2, IEC 61000-6-2, EN 60950	EN 50081-1, IEC 61000-6-2, (EN 50082-2), IEC 950	EN 50081-1, IEC 61000-6-2, (EN 50082-2), IEC 950, 61000-3-2
Approvals	UL, CSA, TÜV		cULus, TÜV	UL, CSA, TÜV, CTick	
Device type	ABL-7RM		ABL-7CEM	ABL-7RE	ABL-7RP
Pages	4		8		

(1) Compatible input voltage, not indicated on the product.

2-phase regulated switch mode power supplies



Industrial applications.

120 and 240 W

~ 2 x 380...415 V 2-phase

⎓ 24 V adjustable

Primary switch mode electronic power supplies.

Integrated, against overloads and short-circuits, with manual and automatic reset.

Output indicator lamp.

–

Direct on ~ rail

cl.B

EN 50081-1, EN 50082-2, EN 60950

–

ABL-7REQ

8

3-phase regulated switch mode power supplies



Industrial applications.
In-line continuous process equipment, machine tools, injection presses, etc.

240 and 480 W 120 W 240...960 W

~ 3 x 380...415 V 3-phase ~ 3 x 400...520 V 3-phase ~ 3 x 400...520 V 3-phase

⎓ 24 V adjustable

Primary switch mode electronic power supplies.

Integrated, against overloads and short-circuits, with manual and automatic reset.

Output indicator lamp.

– Anti-harmonic distortion filter

Direct on ~ rail (except ABL-7UPS 24200 and ABL-7UPS24400)

cl.B

EN 50081-1, EN 50082-2, EN 60950 EN 50081-1, EN 50082-2, EN 60950, IEC 61000-3-2

– cULus, cULus

ABL-7UEQ ABL-7UES ABL-7UPS

8

Regulated switch mode power supplies for AS-Interface



Industrial applications.
Supply of d.c. voltage necessary for AS-Interface systems.

72 W 145 W 2 x 72 W

~ 100...240 V single-phase

⎓ 30 V ⎓ 24 V adjustable

Primary switch mode electronic power supplies.

Integrated, against overloads and short-circuits, overvoltage and undervoltage.

Output and input indicator lamps.

–

Direct on ~ rail

cl.B

EN 50081-1, IEC 61000-6-2, EN 55022 class B

UL, CSA, TÜV

ASI-ABL

Please consult our catalogue "AS-Interface cabling system"

ABL 7RM modular switch mode power supplies

The ABL 7RM range of power supplies is designed to provide the d.c. voltage necessary for the control circuits of control system equipment. Comprising 2 products, this range meets the needs encountered in industrial, commercial and residential applications. These single-phase, modular, electronic switch mode power supplies provide a quality of output current which is suitable for the loads supplied and compatible with the Zelio Logic range, making them ideal partners. Clear guidelines are given on selecting the upstream protection devices which are often used with them, and thus a comprehensive solution is provided which can be used in total safety.

These switch mode power supplies are totally electronic and regulated. The use of electronics makes it possible to significantly improve the performance of these power supplies, which offer:

- very compact size,
- integrated overload, short-circuit, overvoltage and undervoltage protection,
- a very wide range of permissible input voltages, without any adjustment,
- a high degree of output voltage stability,
- good performance,
- considerably reduced weight,
- a modular format allowing integration into panels.

Phaseo power supplies are single-phase. They deliver a voltage which is precise to 3 %, whatever the load and whatever the type of mains supply, within a range of 85 to 264 V for single-phase. Conforming to IEC standards and UL and CSA certified, they are suitable for universal use. The inclusion of overload and short-circuit protection makes downstream protection unnecessary if discrimination is not required.

All the products are fitted with an output voltage adjustment potentiometer in order to be able to compensate for any line voltage drops in installations with long cable runs. These power supplies are designed for direct mounting on 35 and 75 mm \bar{U} rails, or on a mounting plate by means of retractable fixing lugs.

These power supplies are single-phase and two references are available:

- ABL 7RM2401 (24 V \bar{D} /1.3 A).
- ABL 7RM1202 (12 V \bar{D} /1.9 A).

Description

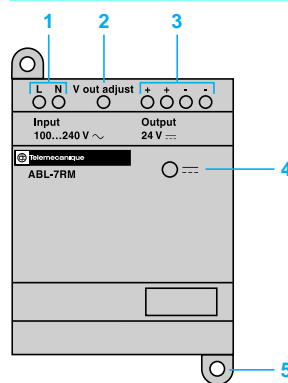

- 1 2.5 mm² screw terminal for connection of the incoming a.c. supply voltage.
- 2 Output voltage adjustment potentiometer.
- 3 2.5 mm² screw terminal for connection of the output voltage.
- 4 LED indicating presence of the d.c. output voltage.
- 5 Retractable fixing lugs.

Technical characteristics

Type of power supply		ABL 7RM1202	ABL 7RM2401
Approvals		UL - CSA - TÜV	
Conforming to standards	Safety	IEC/EN 60950 - IEC/EN 61131-2/A11	
	EMC	EN 50081-1, IEC 61000-6-2 (EN 50082-2)	

Input circuit

LED indication			No	No
Input voltage	Rated values	V	~ 100...240	~ 100...240
	Permissible values	V	~ 85...264	~ 85...264
	Permissible frequencies	Hz	47...63	47...63
	Efficiency at nominal load		> 80%	> 80%
	Current consumption	A	0.5 (100 V)/0.3 (240 V)	0.6 (100 V)/0.4 (240 V)
	Current at switch-on	A	< 20	< 20
	Power factor		0.6	0.6

Output circuit

LED indication			Green LED	Green LED
Nominal output voltage		V	--- 12	--- 24
Nominal output current		A	1.9	1.3
Precision	Output voltage		Adjustable 100 to 120 %	
	Line and load regulation		± 4 %	± 3 %
	Residual ripple - interference	mV	200	250
Micro-breaks	Holding time for I max and Ue min	ms	> 10	> 10
	Protection	Short-circuit		Permanent/Thermal protection
Overcurrent, cold state			< 1.7 In	< 1.6 In
Undervoltage		V	< 10.5	< 19

Operating characteristics

Connections	Input	mm²	1 x 2.5 or 2 x 1.5 screw terminals	
	Output	mm²	1 x 2.5 or 2 x 1.5 screw terminals	
Environment	Storage temperature	°C	-25 to +70	
	Operating temperature	°C	-25 to +55	
	Maximum relative humidity		95 %	
	Degree of protection		IP2x	
	Vibrations		EN 61131-2, IEC 68-2-6 test Fc	
Operating position			Vertical	
MTBF			Not available	
Connections	Series		No	No
	Parallel		Yes (same references)	Yes (same references)
Dielectric strength	Input/output		3000 VAC/50 Hz/1 min	
Protection class conforming to VDE 0106 1			Class II without PE	
Input fuse incorporated			Yes (not interchangeable)	
Emissions	Conducted/radiated		EN 50081-1 (generic standard), EN 55011, EN 55022 Cl:B	
Immunity	Electrostatic discharge		EN 61000-6-2 (generic standard), EN 61000-4-2 (4 kV contact/8 kV air)	
	Electromagnetic		EN 61000-4-3 level 3 (10 V/m)	
	Conducted interference		EN 61000-4-4 level 3 (2 kV), EN 61000-4-6 (10 V)	
	Mains interference		EN 61000-4-11	

Output characteristics

Derating

The ambient temperature is a determining factor which limits the power that an electronic power supply can deliver continuously. If the temperature around the electronic components is too high, their life will be significantly reduced. Conversely, a power supply can deliver more than its rated power if the ambient temperature remains well below the nominal operating temperature.

The maximum ambient temperature for Phaseo power supplies is 55 °C. Below this temperature, uprating is possible up to 110 % of the nominal power. The graph below shows the power (in relation to the nominal power) which the power supply can deliver continuously, according to the ambient temperature.

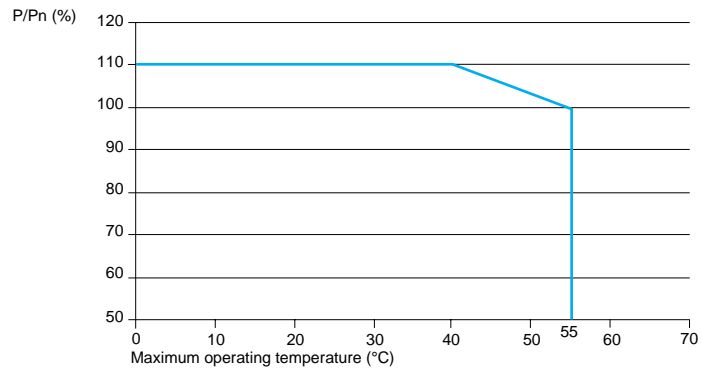

Selection

Upstream protection of power supplies

Mains supply	~ 115 V single-phase			~ 230 V single-phase		
	Type of protection	Thermal-magnetic circuit-breaker	Gg fuse	Thermal-magnetic circuit-breaker	Gg fuse	
Single-pole	GB2 CB●●	-	-	-	-	-
2-pole	GB2 DB●●	C60N	-	GB2 DB●●	C60N	-
ABL 7RM2401	GB2 CB/DB06	MG24516 (1) 1 A 24184	-	GB2 CB/DB07	MG24517 (1) 1 A 24185	-
ABL 7RM1202	GB2 CB/DB06	MG24516 (1) 1 A 24184	-	GB2 CB/DB07	MG17453 (1) 1 A 24185	-

(1) UL certified circuit-breaker

ABL 7RM modular regulated switch mode power supplies

Mains input voltage 47...63 Hz V	Output voltage V	Nominal power W	Nominal current A	Auto-protect reset	Reference	Weight kg
100...240 single-phase wide range	12	22	1.9	auto	ABL 7RM1202	0.180
	24	30	1.3	auto	ABL 7RM2401	0.182

Dimensions

ABL 7RM power supply

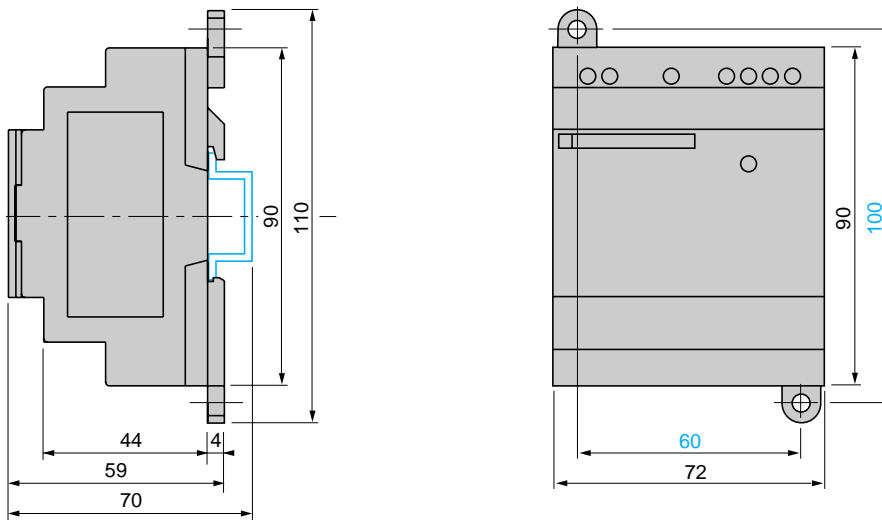

Scheme

ABL 7RM power supply

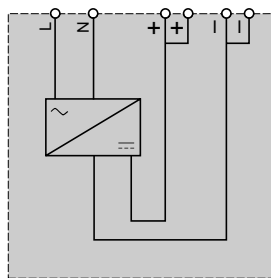

ABL-7 power supplies

The ABL-7 range of power supplies is designed to provide the d.c. voltage necessary for the control circuits of automation system equipment. Split into three families, this range meets all the needs encountered in industrial, commercial and residential applications. Single-phase or 3-phase, of the electronic switch mode type, they provide a quality of output which is suitable for the loads supplied and compatible with the mains supply available in the equipment. Clear guidelines are given for selecting protection devices which are often used with them and thus a comprehensive solution is provided, which can be used in total safety.

Phaseo switch mode power supplies

These switch mode power supplies are totally electronic and regulated. The use of electronics makes it possible to significantly improve the performance of these power supplies, which offer:

- very compact size,
- integrated overload, short-circuit, overvoltage and undervoltage protection,
- a very wide range of permissible input voltages, without any adjustment,
- a high degree of output voltage stability,
- good performance,
- LED indicators on the front panel.

Phaseo power supplies are available in single-phase and 3-phase versions. They deliver a voltage which is precise to 3%, whatever the load and whatever the type of mains supply, within a range of 85 to 264 V for single-phase, or 360 to 550 V for 3-phase. Conforming to IEC standards and UL and CSA certified, they are suitable for universal use. The inclusion of overload and short-circuit protection makes downstream protection unnecessary if discrimination is not required.

ABL-7 RE and ABL-7 RP supplies are also equipped with an output undervoltage control which causes the product to trip if the output voltage drops below 19 V, in order to ensure that the voltage delivered is always usable by the actuators being supplied. All the products are fitted with an output voltage adjustment potentiometer in order to be able to compensate for any line voltage drops in installations with long cable runs. Most of our power supplies are designed for direct mounting on 35 and 75 mm U_T rails.

These power supplies are available in single-phase and 3-phase versions and are split into three families:

Compact single-phase supply ABL-7CEM:

- power less than or equal to 30 W (1.2 A),
- compact size,
- for all low power equipment,
- suitable for use in automation system environments based on the Nano and Twido platforms, or in any automation system configuration requiring a U_T 24 V supply.

Universal single-phase supplies ABL-7RE and ABL-7RP:

- **ABL-7RE**
 - power between 48 W (2 A) and 240 W (10 A),
 - compact size,
 - for all machine equipment,
 - suitable for use in automation system environments based on the Micro and Premium platforms, or in any automation system configuration requiring a U_T 24 V supply.
- **ABL-7RP**
 - power between 60 W (2.5 A) and 240 W (10 A),
 - output voltage available: U_T 12, 24 and 48 V,
 - input filter (PFC) for commercial and residential environments (conforming to standard EN 61000-3-2),
 - two operating modes possible for handling of overload and short-circuit faults:
 - "AUTO" mode which provides automatic restarting of the power supply on elimination of the fault,
 - "MANU" mode which requires manual resetting of the power supply to restart. Resetting is achieved by switching off the mains power.

108700-13-M



ABL 7CEM

43387-15-M



ABL-7RP



Phaseo switch mode power supplies (continued)

3-phase and single-phase process supplies ABL-7U and ABL-7REQ:

■ ABL-7UE

- power between 120 W (5 A) and 480 W (20 A),
- compact size,
- voltages between 3 x 380 V and 3 x 500 V,
- for use in industrial applications, for all in-line or continuous process equipment, machine tools and injection presses, etc.
- suitable for use in automation system environments based on the Premium and Quantum platforms, or in any automation system configuration requiring a $\overline{\text{---}}$ 24 V supply.

■ ABL-7UPS

- power between 120 W (10 A) and 960 W (40 A).
- Identical to the **ABL-7UE** range, this power supply differs in that it includes a filter (PFC) which means that it can be connected directly to the public mains supply, in compliance with standard EN 61000-3-2. This product, for world-wide use, is UL certified.

■ ABL-7 REQ

- power between 120 W (5 A) and 240 W (10 A),
- compact size,
- can be connected to **2-phase** input voltages between 380 V and 415 V, to replace older power supplies connected by only two wires. Economical, more competitive, yet with a smaller input voltage range it can, in certain cases, be used in place of the 3-phase versions.

Using $\overline{\text{---}}$ 24 V

■ Using $\overline{\text{---}}$ 24 V enables so-called protection installations (PELV) to be built. Using PELV is a measure designed to protect people from direct and indirect contact. Measures relating to these installations are defined in publication NF C 12-201 and in standard IEC 364-4-41.

■ The application of these measures to the electrical equipment in machines is defined in standard NF EN 60204-1 and requires:

- that the voltage used is below 60 V d.c. in dry environments and below 30 V in damp environments,
- the connection of one side of the PELV circuit, or one point of the source, to the equipotential protection circuit associated with higher voltages,
- the use of switchgear and control gear on which measures have been taken to ensure "safety separation" between power circuits and control circuits.

■ A safety separation is necessary between power circuits and control circuits in PELV circuits. Its aim is to prevent the appearance of dangerous voltages in $\overline{\text{---}}$ 24 V safety circuits.

■ The reference standards involved are:

- IEC 61558-2-6 and EN 61558-2-6 (safety transformers),
- IEC 664 (coordination of isolation).

Telemecanique power supplies meet these requirements.

■ Moreover, to ensure that these products will operate correctly in relation to the demands of their reinforced isolation, it is recommended that they be mounted and wired as indicated below:

- they should be placed on an earthed mounting plate or rail,
- they should be connected using flexible cables, with a maximum of two wires per connection, and tightened to the nominal torque,
- conductors of the correct insulation class must be used.

■ If the d.c. circuit is not connected to an equipotential protection conductor, an earth leakage detector will indicate any accidental earth faults (please consult your Regional Sales Office).

Operating voltage

■ The permissible tolerances for the operating voltage are listed in publications IEC 1131-2 and DIN 19240.

■ For nominal voltage $U_n = \overline{\text{---}}$ 24 V, the extreme operating values are from - 15 % to + 20 % of U_n , whatever the supply fluctuations in the range -10 % to + 6 % (defined by standard IEC 38) and load variations in the range 0-100 % of I_n .

All Telemecanique $\overline{\text{---}}$ 24 V power supplies are designed to provide a voltage within this range.

■ It may be necessary to use a voltage measurement relay to detect when the normal voltage limits are being surpassed and to deal with the consequences of this (please consult your Regional Sales Office).

Selection of power supplies

The characteristics to be taken into account when selecting a power supply are:

- the required output voltage and current,
- the mains voltage available in the installation.

An initial selection can be made using the table opposite.

This may however result in several products being selected as suitable.

Other selection criteria must therefore be taken into account.

■ The quality of the mains power supply

The Phaseo range is the solution because it guarantees precision to 3% of the output voltage, whatever the load current and the input voltage. In addition, the wide input voltage range of Phaseo power supplies allows them to be connected to all mains supplies within the nominal range, without any adjustment.

The Phaseo RP family can also be connected to \approx 110 and 220 V emergency supplies.

■ Harmonic pollution (power factor)

The current drawn by a power supply is not sinusoidal. This leads to the existence of harmonic currents which pollute the mains supply. European standard EN 61000-3-2 limits the harmonic currents produced by power supplies. This standard covers all devices between 75 W and 1000 W, drawing up to 16 A per phase, and connected directly to the public mains power supply. Devices connected downstream of a private, low voltage general transformer are therefore excluded.

Regulated switch mode supplies always produce harmonic currents; a filter circuit (Power Factor Correction or PFC) must therefore be added to comply with standard EN 61000-3-2.

Phaseo ABL-7RP and ABL-7UPS power supplies conform to standard EN 61000-3-2 and can therefore be connected directly to public mains power supplies.

■ Electromagnetic compatibility

Levels of conducted and radiated emissions are defined in standards EN 55011 and EN 55022.

The majority of products in the Phaseo range have class B certification and can be used without any restrictions due to their low emissions.

ABL-7CEM24003 and ABL-7CEM24006 power supplies have class A certification. It is recommended that they should not be used in the following equipment: trains, aircraft, nuclear applications and in any environment where malfunctioning could cause serious injuries or lead to death. These products are designed for use in industrial equipment and are not suitable for use in residential environments.

■ Behaviour in the event of short-circuits

Phaseo power supplies are equipped with an electronic protection device. This protection device resets itself automatically on elimination of the fault (around 1 second for ABL-7 RE/RP, around 3 seconds for ABL-7 UE/UP/REQ) which avoids having to take any action or change a fuse. In addition, the Phaseo ABL-7RP/U/REQ ranges allow the user to select the reset mode in the event of a fault:

- in the "AUTO" position, resetting is automatic,
- in the "MANU" position, resetting occurs after elimination of the fault and after switching the mains power off and back on.

This feature allows Phaseo ABL-7RP/U/REQ power supplies to be used in installations where the risks associated with untimely restarting are significant.

■ Behaviour in the event of phase failure

In the event of failure of one phase, all Phaseo 3-phase power supplies switch to relaxation mode for as long as the input voltage is < 450 V.

For operation on higher voltages (e.g. 480 V), use of an upstream GV2 type residual current protection device is recommended.

■ Selection of reset mode

- on the ABL-7RP family of products:

By microswitch on the front panel of the product.

- on the ABL-7U/REQ family of products:

By jumper on the front panel. **Warning: selection of the function is only possible after the mains power supply has been switched off for at least 5 minutes.** The jumper is moved using a pair of insulated, flat-nose pliers.

Selection according to application characteristics

Type of mains supply	Single-phase				2-phase	3-phase			
Rated mains supply voltage	\sim 100...240 V 50/60 Hz \equiv 110... 220 V (1) Wide range				100...240 V 50/60 Hz Wide range	2 x 380...415 V 50/60 Hz	3 x 380...415 V 50/60 Hz	3 x 400...520 V 50/60 Hz Wide range	3 x 380...520 V 50/60 Hz Wide range
Permissible variation	85...264 V, 47...63 Hz \equiv 100...250 V (1), \equiv 105...370 V (2)				85...264 V 47...63 Hz	340...460 V 47...63 Hz	340...460 V 47...63 Hz	360...550 V 47...63 Hz	340...550 V 47...63 Hz
Output voltage	12 V	48 V	24 V	24 V	24 V	24 V	24 V	24 V	24 V
Output current	0.3 A		ABL-7CEM24003						
	0.6 A		ABL-7CEM24006						
	1.2 A		ABL-7CEM24012						
	2 A			ABL-7RE2402					
	2.5 A	ABL-7RP4803							
	3 A		ABL-7RP2403	ABL-7RE2403					
	5 A	ABL-7RP1205		ABL-7RP2405	ABL-7RE2405	ABL-7REQ24050		ABL-7UES24050	
	10 A		ABL-7RP2410	ABL-7RE2410	ABL-7REQ24100	ABL-7UEQ24100			ABL-7UPS24100
	20 A						ABL-7UEQ24200		ABL-7UPS24200
40 A								ABL-7UPS24400	
Conforming to EN 61000-3-2	Yes (not applicable for ABL-7CEM)				No	No	No	No	Yes
Integrated automatic protection	Yes Automatic or manual restart on ABL-7RP Automatic restart only on ABL-7CEM				Yes Automatic restart	Yes Automatic or manual restart			

(1) Values for **ABL-7RP** power supplies, not indicated on the product.

(2) Values for **ABL-7CEM** power supplies, not indicated on the product.

Technical characteristics				
Type of power supply		ABL-7CEM	ABL-7RE	ABL-7RP
Product certifications		cULus, TÜV	UL, CSA, TÜV, CTick	
Conforming to standards		UL 508	UL 508, CSA 22.2 n° 950	
Safety		IEC/EN 60950, FELV		IEC/EN 61496-1-2, FELV
EMC		EN 50081-2, EN 50082-2	EN 50081-1, IEC 61000-6-2 (EN 50082-2)	
Low frequency harmonic currents		–	–	EN 61000-3-2
Input circuit				
LED indication		–	Orange LED	Orange LED
Input voltages	Rated values	V ~ 100...240, --- 110...220 compatible (1)	~ 100...240	~ 100...240, --- 110...220 compatible (1)
	Permissible values	V ~ 85...264, --- 105...370 compatible (1)	~ 85...264 single-phase	~ 85...264, --- 100...250 compatible (1)
Permissible frequencies		Hz 47...63		
Efficiency at nominal load		> 70 %	> 85 %	
Current consumption	Ue = 240 V	A 0.1 (7 W)/0.2 (15 W)/0.45 (30 W)	0.6 (48 W)/0.83 (72 W) 1.2 (120 W)/2.5 (240 W)	0.4 (72 W)/0.6 (120 W) 1.3 (240W)
	Ue = 100 V	A 0.17 (7 W)/0.3 (15 W)/0.68 (30 W)	1.2 (48 W)/1.46 (72 W) 1.9 (120 W)/3.6 (240 W)	0.8 (72 W)/1 (120 W)/2.8 (240 W)
Current at switch-on		A < 50	< 30	
Power factor		0.45 approx.	0.65 approx.	0.98 approx.
Output circuit				
LED indication		Green LED	Green LED	Green LED
Nominal output voltage (U out)		V --- 24		12, 24 and 48
Nominal output current		A 0.3/0.6/1.2	2/3/5/10	2.5/5/10
Precision	Output voltage	Adjustable from 90 to 110 %		Adjustable from 100 to 120 %
	Line and load regulation	2 % max		± 3 %
	Residual ripple - interference	mV < 200 (peak-peak)		
Micro-breaks	Holding time at I max and Ve min	ms > 20	> 10	> 20
Temporary overloads	Permissible inrush current (U out >19V)	See curves page 15		
Protection	Short-circuit	Permanent/automatic restart	Permanent/automatic restart	Permanent/automatic restart or restart after switching off mains power
	Overload	1.05 In	1.1 In	
	Overvoltage	U > 1.2	Tripping if U > 1.5 Un	
	Undervoltage	–	Tripping if U < 0.8 Un	
Operating and environmental characteristics				
Connections	Input	mm² 2 x 2.5 + earth		
	Output	mm² 2 x 2.5	2 x 2.5 + earth, multiple output, depending on model	
Ambient conditions	Storage temperature	°C - 25... + 70		
	Operating temperature	°C - 10... + 60 (derating as from 50° C, mounted vertically)	0... + 60 (derating as from 50° C, mounted vertically)	
	Max. relative humidity	20...90 %	95 % without condensation or dripping water	
	Degree of protection	IP 20 conforming to IEC 529		
	Vibrations	Conforming to IEC 61131-2		
Operating position		Vertical and horizontal (see derating curve, page 14)	Vertical	
MTBF at 40°		> 100 000 h		
Connections	Series	Possible (see page 15)		
	Parallel	No	Possible (max. temperature 50° C)	
Dielectric strength	Input/output	3000 V/50 and 60 Hz 1 min	3000 V/50 and 60 Hz 1 min	
	Input/earth	2000 V/50 and 60 Hz 1 min	3000 V/50 and 60 Hz 1 min	
	Output/earth (and output/output)	500 V/50 and 60 Hz 1 min	500 V/50 and 60 Hz 1 min	
Input fuse incorporated		Yes (not interchangeable)		
Disturbance	Conducted	EN 50081-2 (generic)	EN 50081-1	
	Radiated	EN 55011/EN 55022 class A (7 and 15 W) EN 55011/EN 55022 class B (30W)	EN 55011/EN 55022 class B	
Immunity		IEC 61000-6-2 (generic)		
	Electrostatic discharge	EN 61000-4-2 (4 kV contact/8 kV air)		
	Electromagnetic	EN 61000-4-3 level 3 (10 V/m)		
	Conducted interference	EN 61000-4-4 level 3 (2 kV) , EN 61000-4-5, EN 61000-4-6 level 3, EN 61000-4-8 level 4		
	Mains interference	EN 1000-4-11 (voltage drops and cuts)		

(1) Compatible input voltage, not indicated on the product.

Technical characteristics

Type of power supply	ABL-7REQ24●	ABL-7UEQ24●	ABL-7UES24●	ABL-7UPS24●
Product certifications	-			cULus, cULus
Conforming to standards				
Safety	EN 60950, FELV			
EMC	EN 50081-1, EN 50082-2			
Low frequency harmonic currents	-			EN 61000-3-2

Input circuit

LED indication	-				
Input voltages					
Rated values	V	~ 2 x 380...415	~ 3 x 380...415	~ 3 x 400...520	~ 3 x 400...520
Permissible values	V	~ 2 x 340...460	~ 3 x 340...460	~ 3 x 360...550	~ 3 x 360...550
Permissible frequencies	Hz	50...60			
Efficiency at nominal load		> 85 %	> 90 %		
Current consumption Ue = 400 V	A	0.65 (120 W)/1.2 (240 W)	0.75 (240 W)/1.5 (480 W)	0.7 (240 W)/1.2 (480 W)/1.7 (960 W)	
Current at switch-on	A	< 35			
Power factor		0.6	0.55	0.7	0.7/0.9 (960 W)
2-phase operating mode	V	-		Relaxation if input voltage < ~ 450	

Output circuit

LED indication	Green LED				
Nominal output voltage (U out)	V	--- 24			
Nominal output current	A	5/10	10/20	5	10/20/40
Precision					
Output voltage	Adjustable from 100 to 116%				
Line and load regulation	1 % max				
Residual ripple - interference	mV	< 200 (peak-peak)			
Micro-breaks					
Holding time for I max and Ve min	ms	15	10		Between 8 and 13
Temporary overloads					
Permissible inrush current (U out >19V)	See curves, page 15				
Protection					
Short-circuit	Permanent/automatic or normal restart				
Overload	1.20 In < 50 ms				
Overvoltage	V	28.5 typical			
Undervoltage	V	19 typical			

Operating and environmental characteristics

Connections	Input	mm ²	2 x 1.5...2.5 mm ² + earth			
	Output	mm ²	4 x 1.5...2.5 mm ²	4 x 4...6 mm ²	4 x 1.5...2.5 mm ²	4 x 1.5...2.5 mm ² + earth (240 W) 4 x 4...6 mm ² + earth (480 W) 4 x 4...10 mm ² + earth (960 W)
Ambient conditions	Storage temperature	°C	- 25...+ 70			
	Operating temperature	°C	0° C...+ 60° C			
	Maximum relative humidity		30...90 %			
	Degree of protection		IP 20 or IP XXB			
	Vibrations		Conforming to IEC 61131-2			
Operating position						Vertical
MTBF						> 100 000 h
Connections	Series	Possible				
	Parallel	See page 15				
Dielectric strength	Input/output	3750 V/50 and 60 Hz 1 min				
	Input/earth	3500 V/50 and 60 Hz 1 min				
	Output/earth (and output/output)	500 V/50 and 60 Hz 1 min				
Input fuse incorporated						No
Disturbance	Conducted/radiated	EN 55011/EN 5022 - class B				
Immunity	Electrostatic discharge	EN 61000-4-2 (4 kV contact/8 kV air)				
	Electromagnetic	EN 61000-4-3 level 3 (10 V/m)				
	Conducted interference	EN 61000-4-4 level 3 (2 kV), EN 61000-4-5, EN 61000-4-6 level3, EN 61000-4-8 level 4 (for ABL-7RE/RP)				
	Mains interference	EN 61000-4-11 (voltage drops and cuts)				

Derating

The ambient temperature is a determining factor which limits the power that an electronic power supply can deliver continuously. If the temperature around the electronic components is too high, their life will be significantly reduced. Conversely, a power supply can deliver more than its nominal power if the ambient temperature remains largely below the rated operating temperature.

The rated ambient temperature for Phaseo power supplies is 50 °C. Above this, derating is necessary up to a maximum temperature of 60 °C.

The graph below shows the power (in relation to the nominal power) which the power supply can deliver continuously, according to the ambient temperature.

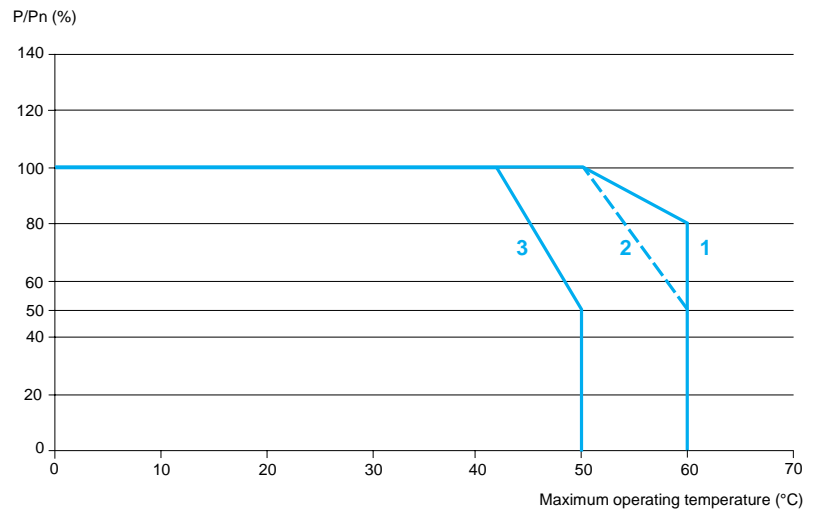

- 1 ABL-7RE, ABL-7RP, ABL-7U mounted vertically
- 2 ABL-7CEM mounted vertically
- 3 ABL-7CEM mounted horizontally

Derating should be considered in extreme operating conditions:

- intensive operation (output current permanently close to the nominal current, combined with a high ambient temperature),
- output voltage set above 24 V (to compensate for line voltage drops, for example),
- parallel connection to increase the total power.

General rules to be complied with

Intensive operation	See derating on above graph. Example for ABL-7RE: - without derating, from 0 °C to 50 °C, - derating of nominal current by 2%, per additional °C, up to 60 °C.
Rise in output voltage	The nominal power is fixed. Increasing the output voltage means that the current delivered must be reduced
Parallel connection to increase the power (except ABL-7CEM)	The total power is equal to the sum of the power supplies used, but the maximum ambient temperature for operation is 50 °C. To improve heat dissipation, the power supplies must not be in contact with each other

In all cases, there must be adequate convection round the products to ensure easier cooling. There must be a clear space of 50 mm above and below Phaseo power supplies and of 15 mm at the sides.

Load limit

ABL-7CEM24●●●

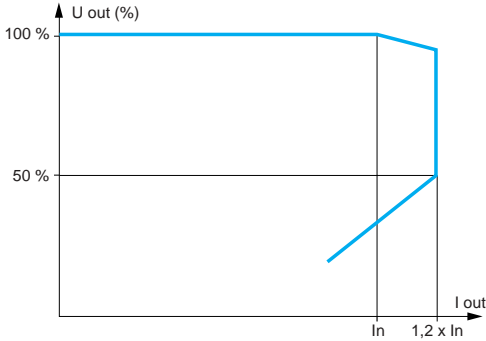

ABL-7RE24●●/ABL-7RP●●●●●
ABL-7U●●24●●/ABL-7REQ●●●●●

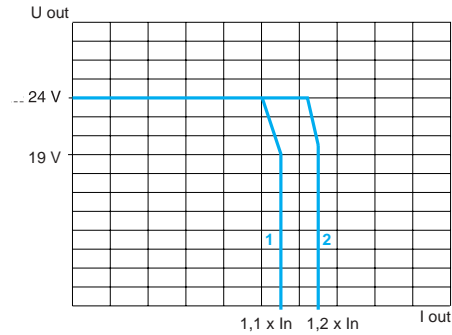

1 ABL-7RE24●●/ABL-7RP●●●●●
2 ABL-7U●●24●●/ABL-7REQ●●●●●

Temporary overloads

ABL-7CEM

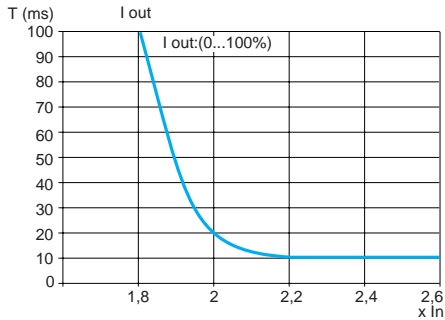

ABL-7RE/ABL-7RP

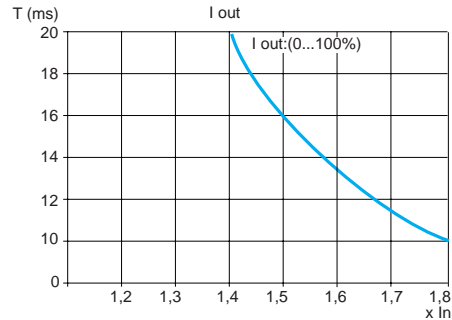

ABL-7U

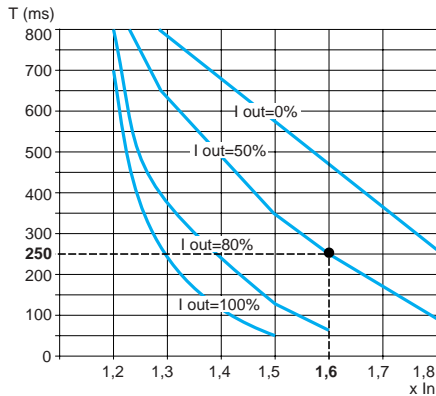

Example: For an ABL-7UPS24●●● power supply with 50 % loading. (I out = 50 %), this power supply can absorb a current peak of 1.6 x In for 250 ms with an output voltage ≥ 19 V.

Series or parallel connection

Series connection

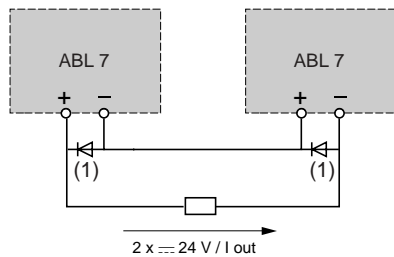

Parallel connection

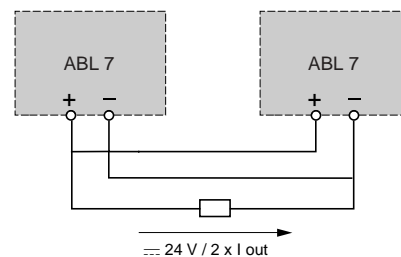

Family	Series	Parallel
ABL-7CEM	2 products max (1)	No
ABL-7RE/RP	2 products max	2 products max
ABL-7U/REQ	2 products max	2 products max

(1) 2 Shottky diodes 2 A/100 V on ABL-7CEM only.

ABL-7CEM, ABL-7RE and ABL-7RP power supplies: protection of the power supply line

Type of mains supply	~ 115 V single-phase			~ 230 V single-phase		
Type of protection	Thermal-magnetic circuit-breaker		gG fuse	Thermal-magnetic circuit-breaker		gG fuse
	GB2	C60N		GB2	C60N	
ABL-7CEM24003	GB2-CD06	24183 MG24516 (1)	2A	GB2-CD07	24184 MG24517 (1)	2 A
ABL-7CEM24006	GB2-CD07	24184 MG24517 (1)	2A	GB2-CD08	24185 MG24518 (1)	2 A
ABL-7CEM24012	GB2-CD07	24184 MG24517 (1)	2A	GB2-CD08	24185 MG24518 (1)	2 A
ABL-7RE2402	GB2-●B07	MG24517 (1)	2A	GB2-DB06	MG24516 (1)	2 A
ABL-7RE2403	GB2-●B07	MG24517 (1)	2 A	GB2-DB06	MG24516 (1)	2 A
ABL-7RE2405	GB2-●B08	MG24518 (1)	4 A	GB2-DB07	MG17453 (1)	2 A
ABL-7RE2410	GB2-●B12	MG17454 (1)	6 A	GB2-DB08	MG24518 (1)	4 A
ABL-7RP2403	GB2-●B07	MG24517 (1)	2 A	GB2-DB07	MG24516 (1)	2 A
ABL-7RP2405	GB2-●B07	MG24517 (1)	2 A	GB2-DB07	MG24516 (1)	2 A
ABL-7RP2410	GB2-●B09	MG24519 (1)	4 A	GB2-DB07	MG24516 (1)	2 A
ABL-7RP4803	GB2-●B07	MG24517 (1)	2 A	GB2-DB07	MG24516 (1)	2 A

ABL-7REQ power supplies: protection of the power supply line

Type of mains supply	~ 400 V 2-phase		
Type of protection	Thermal-magnetic circuit-breaker		gG fuse
2-pole	GB2-DB●●	C60N	
ABL-7REQ24050	DB07	24100	10 A
ABL-7REQ24100	DB08	24100	10 A

ABL-7UEQ, ABL-7UES and ABL-7UPS power supplies: protection of the power supply line

Type of mains supply	~ 400...480 V 3-phase		
Type of protection	Thermal-magnetic circuit-breaker		gG fuse
2-pole	GV2-ME●●	C60N	
ABL-7UEQ24100	GV2-ME08 (1)	24212	4 A
ABL-7UEQ24200	GV2-ME08 (1)	24213	6 A
ABL-7UES24050	GV2-ME08 (1)	24210	2 A
ABL-7UPS24100	GV2-ME08 (1)	24210	2 A
ABL-7UPS24200	GV2-ME08 (1)	24211	3 A
ABL-7UPS24400	GV2-ME08 (1)	24212	4 A

(1) UL certified circuit-breaker.

ABL 7CEM single-phase regulated switch mode power supplies

Mains input voltage 47...63 Hz	Output voltage	Nominal power	Nominal current	Auto-protect reset	Conforming to standard EN 61000-3-2	Reference	Weight
V	\equiv V	W	A				kg
\sim 100...240 single-phase wide range \equiv 110...220 (1)	24	7	0.3	auto	no	ABL-7CEM24003	0.150
		15	0.6	auto	no	ABL-7CEM24006	0.180
		30	1.2	auto	no	ABL-7CEM24012	0.220



ABL-7CEM

ABL-7RE single-phase regulated switch mode power supplies

Mains input voltage 47...63 Hz	Output voltage	Nominal power	Nominal current	Auto-protect reset	Conforming to standard EN 61000-3-2	Reference	Weight
V	\equiv V	W	A				kg
\sim 100...240 single-phase wide range	24	48	2	auto	no	ABL-7RE2402	0.520
		72	3	auto	no	ABL-7RE2403	0.520
		120	5	auto	no	ABL-7RE2405	1.000
		240	10	auto	no	ABL-7RE2410	2.200

ABL-7RE2405
ABL-7RP2405
ABL-7RP4803

ABL-7RP single-phase regulated switch mode power supplies

Mains input voltage 47...63 Hz	Output voltage	Nominal power	Nominal current	Auto-protect reset	Conforming to standard EN 61000-3-2	Reference	Weight
V	\equiv V	W	A				kg
\sim 100...240 single-phase wide range \equiv 110...220 (1)	12	60	5	auto/man	yes	ABL-7RP1205	1.000
	24	72	3	auto/man	yes	ABL-7RP2403	0.520
		120	5	auto/man	yes	ABL-7RP2405	1.000
		240	10	auto/man	yes	ABL-7RP2410	2.200
		48	144	2.5	auto/man	yes	ABL-7RP4803



ABL-7REQ

ABL-7REQ 2-phase regulated switch mode power supplies

Mains input voltage 47...63 Hz	Output voltage	Nominal power	Nominal current	Auto-protect reset	Conforming to standard EN 61000-3-2	Reference	Weight
V	\equiv V	W	A				kg
\sim 380...415	24	120	5	auto/man	no	ABL-7REQ24050	0.850
		240	10	auto/man	no	ABL-7REQ24100	1.200

ABL-7U 3-phase regulated switch mode power supplies

Mains input voltage 47...63 Hz	Output voltage	Nominal power	Nominal current	Auto-protect reset	Conforming to standard EN 61000-3-2	Reference	Weight
V	\equiv V	W	A				kg
\sim 3x380...415	24	240	10	auto/man	no	ABL-7UEQ24100	1.200
		480	20	auto/man	no	ABL-7UEQ24200	2.100
\sim 3x400...520	24	120	5	auto/man	no	ABL-7UES24050	1.300
		240	10	auto/man	yes	ABL-7UPS24100	1.300
		480	20	auto/man	yes	ABL-7UPS24200	2.300
		960	40	auto/man	yes	ABL-7UPS24400	4.500



ABL-7UPS

(1) Compatible input voltage, not indicated on the product.

Power supplies and transformers

Power supplies for d.c. control circuits
Phaseo regulated switch mode power supplies

ABL-7RE24●●/ABL-7RP●●●●
Common side view
Mounting on 35 and 75 mm rails

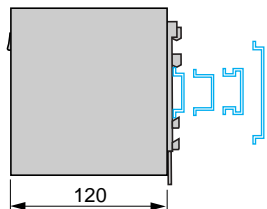

ABL-7RE2402/2403
ABL-7RP2403

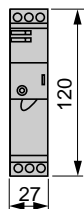

ABL-7RE2405
ABL-7RP1205/2405/4803

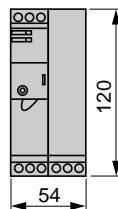

ABL-7RE2410
ABL-7RP2410

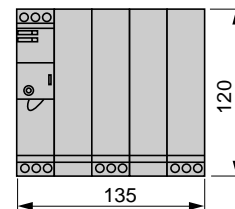

ABL-7CEM24●●●
ABL-7CEM24003

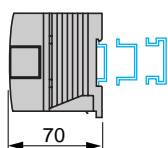

ABL-7CEM24006/
ABL-7CEM24012

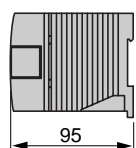

Common front view

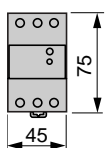

ABL-7REQ24●●●/ABL-7UEQ24100/ABL-7UES24050/
ABL-7UPS24100

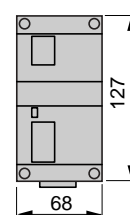
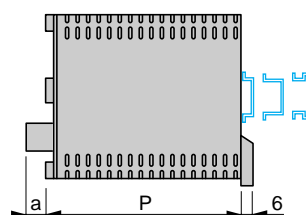

Panel mounting

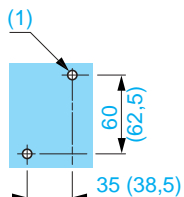

(1) 2 x M4 or 2 x Ø4.5

ABL-	P mm	a mm
7REQ24050	130	-
7REQ24100	154	-
7UEQ24100	154	-
7UES24050	171	15
7UPS24100	171	15

ABL-7UEQ24200

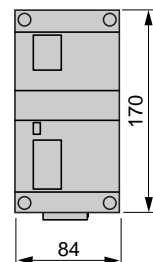
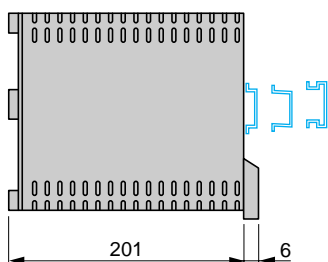

ABL-7UPS24200

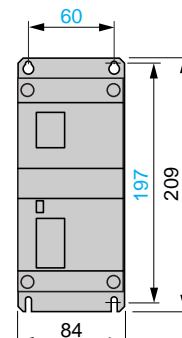
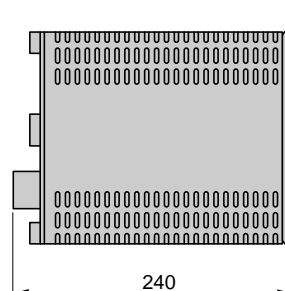

ABL-7UPS24400

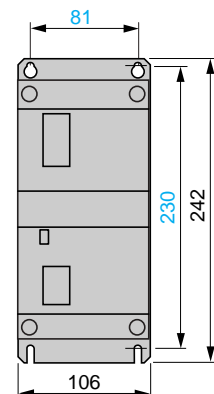
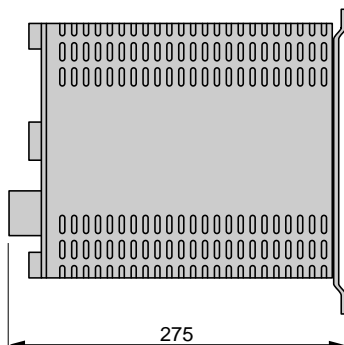

Power supplies and transformers

Power supplies for d.c. control circuits

Phaseo regulated switch mode power supplies

ABL-7RE2402/2403

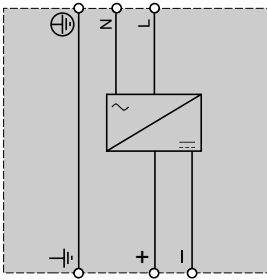

ABL-7RE2405

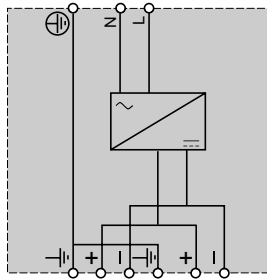

ABL-7RE2410

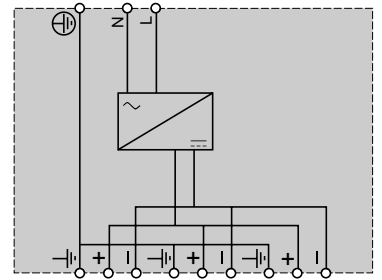

ABL-7RP2403

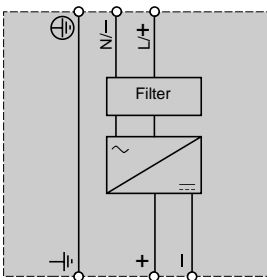

ABL-7RP1205/2405/4803

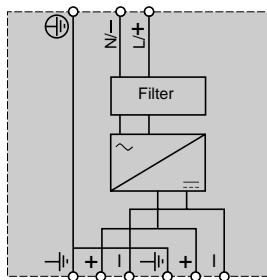

ABL-7RP2410

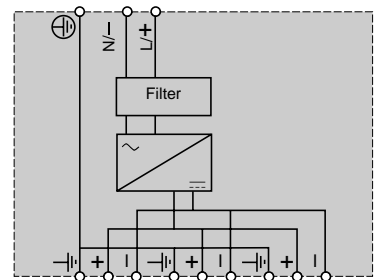

ABL-7CEM24●●●

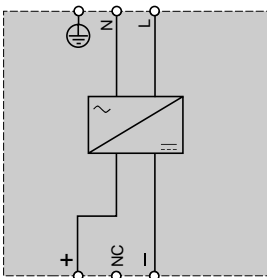

ABL-7REQ24●●●

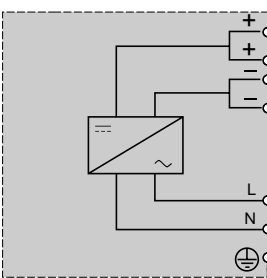

ABL-7UE●●●●●

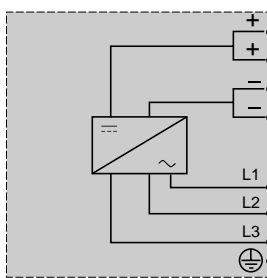

ABL-7UP●●●●●

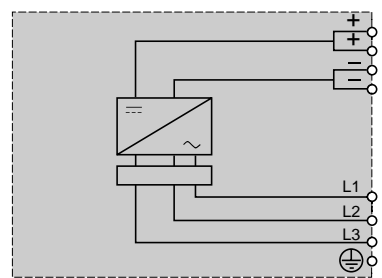

Power supplies and transformers

Phaseo regulated switch mode power supplies for AS-Interface cabling system

Power supplies for AS-Interface

Consistent with the standard Phaseo line, the range of ASI ABL power supplies is designed to deliver a d.c. voltage, as required by networks operating under the AS-Interface cabling system. Three versions are available to meet all needs encountered in industrial applications, in enclosures, cells or floor-standing enclosures. These single-phase, electronic, switch mode power supplies guarantee the quality of the output current, in accordance with the electrical characteristics and conforming to standard EN 50295.

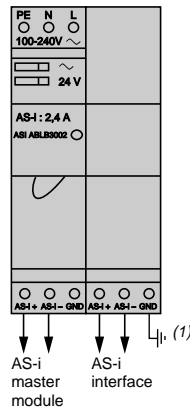

■ ASI ABLB300●

Operating on a 100 to 240 V a.c. supply, this power supply delivers a voltage of 30 V d.c. Available in 2.4 and 4.8 A ratings, the parallel output terminal blocks allow the bus to be connected separately to the slaves and the master. Input and output LEDs allow fast and continuous diagnostics.

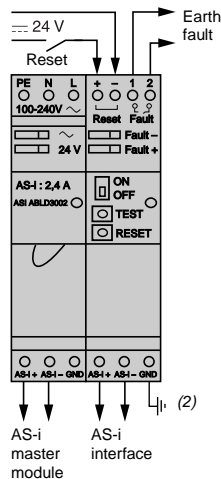

■ ASI ABLD300●

Operating on a 100 to 240 V a.c. supply, this power supply delivers a voltage of 30 V d.c. Available in 2.4 and 4.8 A ratings, it allows diagnosis and management of earth faults on AS-Interface networks. In the event of an earth fault, the Phaseo power supply trips out, thus stopping dialogue on the bus. Restarting is only possible after deliberate acknowledgement of the fault. Two I/O are provided, which may be used to monitor status. The parallel output terminal blocks are used to connect the bus separately to the slaves and the master. Input, output and fault LED's allow fast and continuous diagnostics.

Warning: the earth (GND) (2) connection must be made. In the event of disconnection, the built-in detector becomes inoperative. To obtain earth connection diagnostics, it is recommended that an ASI ABLB300● power supply be used together with insulation relay RMO PAS 101.

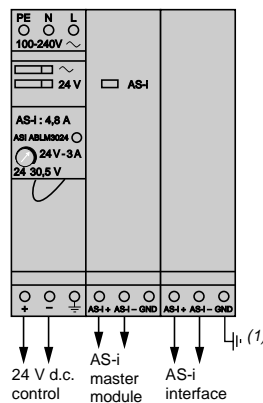

■ ASI ABLM3024

Operating on a 100 to 240 V a.c. supply, this product delivers two d.c. outputs which are totally independent in the way they operate.

Two output voltages - 30 V d.c./2.4 A (AS-Interface supply) and 24 V d.c./3 A - are available, so making it possible to supply the control equipment without an additional power supply. Input and output LEDs allow fast and continuous diagnostics.

(1) Recommended connection.

(2) Compulsory connection.

Technical characteristics						
Type of power supply		ASI ABLB3002	ASI ABLB3004	ASI ABLD3002	ASI ABLD3004	ASI ABLM3024
Functions		Supply to the AS-Interface system				24V $\overline{\text{---}}$ supply
Product certifications		UL 508, CSA 22-2 n° 950				
Conforming to standards	Safety	EN 60950, TÜV				
	EMC	EN 50081-1, IEC 61000-6-2, EN 55022 class B				
	Low frequency harmonic currents	No				
Input circuit						
LED indication		Orange LED				
Input voltage	Rated values	V	\sim 100...240			
	Permissible values	V	\sim 85...264			
	Permissible frequencies	Hz	47...63			
	Efficiency at nominal load	%	> 83			
	Current consumption		0.5	1	0.5	1
	Current at switch-on	A	< 30			
	Power factor		> 0.65			
Output circuit						
LED indication		Green LED				
Nominal output voltage		V	$\overline{\text{---}}$ 30 (AS-Interface)			
Nominal output current		A	2.4	4.8	2.4	4.8
Precision	Adjustable output voltage	V	-			
	Line and load regulation		3 %			
	Residual ripple - interference	mV	300 - 50			
Micro-breaks	Holding time for I max and Ve min	ms	10			
Protection	Short-circuit		Permanent/automatic restart after elimination of the fault			
	Overload		1.1 In			
	Overvoltage		Tripping if $U > 1.2 U_n$			
	Undervoltage		Tripping if $U < 0.95 U_n$			
Operating characteristics						
Connections	Input	mm ²	2 x 2.5 screw terminals + earth			
	Output	mm ²	2 x 2.5 screw terminals + earth, multiple output			
Environment	Storage temperature	°C	- 25 to + 70			
	Operating temperature	°C	0 to + 60 (derating from 50)			
	Maximum relative humidity		95 % (without condensation or dripping water)			
	Degree of protection		IP 20 (conforming to IEC 529)			
	Vibration		EN 61131-2			
Operating position		Vertical				
MTBF		h	> 100000 (conforming to Bell core, at 40 °C)			
Dielectric strength	Input/output		3000 V/50 Hz/1 mm			
	Input/earth		3000 V/50 Hz/1 mm			
	Output/earth (and input/output)		500 V/50 Hz/1 mm			
Input fuse incorporated		Yes (not interchangeable)				
Emissions	Conducted/radiated		Class B (conforming to EN 55022)			
Immunity	Electrostatic discharge		EN 61000-4-2 (4 kV contact/8 kV air)			
	Electromagnetic		EN 61000-4-3 level 3 (10 V/m)			
	Conducted interference		EN 61000-4-4 level 3 (2 kV), EN 61000-4-6 (10 V)			
	Mains interference		EN 61000-4-11			

Output characteristics

Derating

The ambient temperature is a determining factor which limits the power that an electronic power supply can deliver continuously. If the temperature around the electronic components is too high, their life will be significantly reduced. The graph below shows the power (in relation to the nominal power) which the power supply can deliver continuously, according to the ambient temperature.

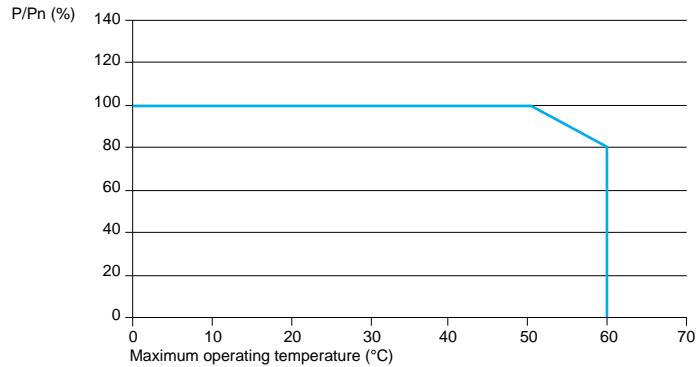

Selection

Upstream protection of power supplies for use on the AS-Interface system

Mains supply	~ 115 V single-phase		~ 230 V single-phase	
	Thermal-magnetic circuit-breaker	Gg fuse	Thermal-magnetic circuit-breaker	Gg fuse
Single-pole	GB2 CB●●			
2-pole	GB2 DB●● C60N		GB2 DB●● C60N	
ASI ABLB3002	GB2 ●B07	MG24517 (1) 2 A	GB2 DB06	MG24516 (1) 2 A
ASI ABLB3004	GB2 ●B08	MG24518 (1) 4 A	GB2 DB07	MG17453 (1) 2 A
ASI ABLD3002	GB2 ●B07	MG24517 (1) 2 A	GB2 DB06	MG24516 (1) 2 A
ASI ABLD3004	GB2 ●B08	MG24518 (1) 4 A	GB2 DB07	MG17453 (1) 2 A
ASI ABLM3024	GB2 ●B07	MG24517 (1) 2 A	GB2 DB06	MG17453 (1) 2 A

(1) UL certified circuit-breaker.

Function diagram

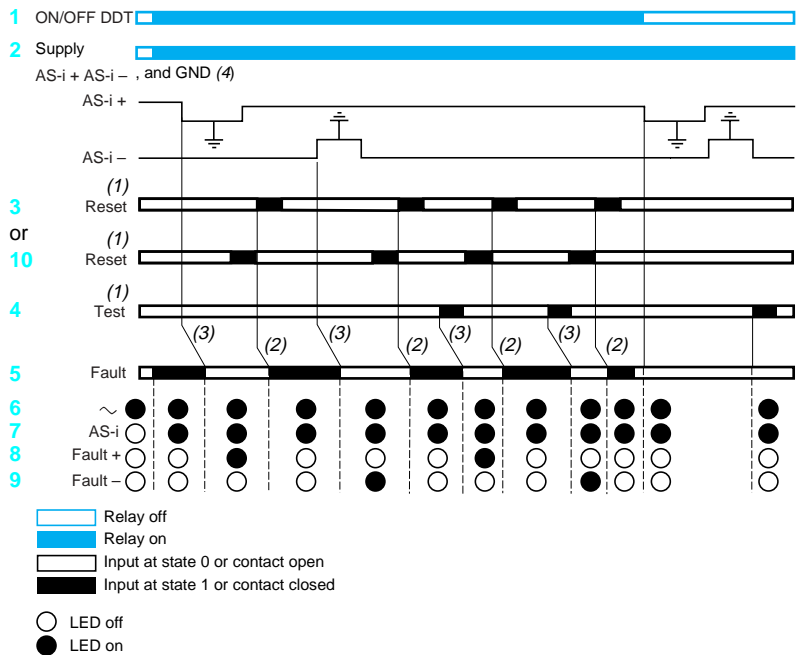
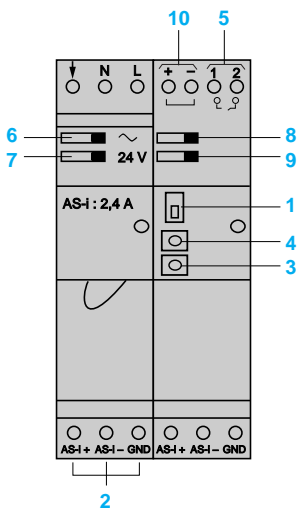

(1) 30 ms min.

(2) 15 ms.

(3) 20 ms.

(4) Warning: the earth fault detector will only operate if the earth (GND) terminal is connected.

ASI ABL regulated switch mode power supplies

Mains input voltage 47...63 Hz V	Output voltage V	Nominal power W	Nominal current A	Auto-protect reset	Earth fault detection	Reference	Weight kg
100...240 single-phase wide range	30	72	2.4	auto	no	ASI ABLB3002	0.800
		145	4.8	auto	no	ASI ABLB3004	1.300
		72	2.4	auto	yes	ASI ABLD3002	0.800
		145	4.8	auto	yes	ASI ABLD3004	1.300
	30 + 24	2 x 72	2.4 + 3	auto	no	ASI ABLM3024	1.300

Dimensions

Common side view
Mounting on 35 and 75 mm rails

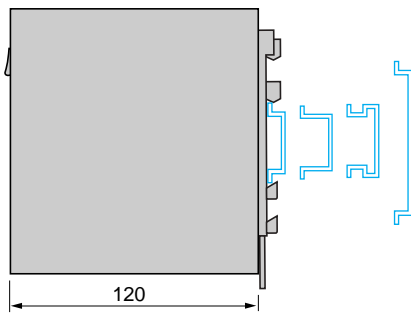

ASI ABLB3002
ASI ABLD3002

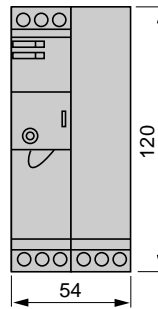

ASI ABLM3024
ASI ABL3004

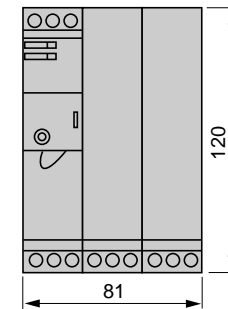

Schemes

ASI ABLB300●

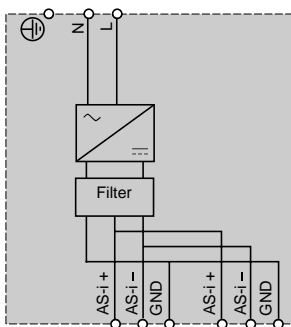

ASI ABLD300●

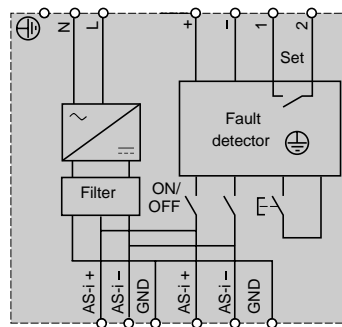

ASI ABLM3024

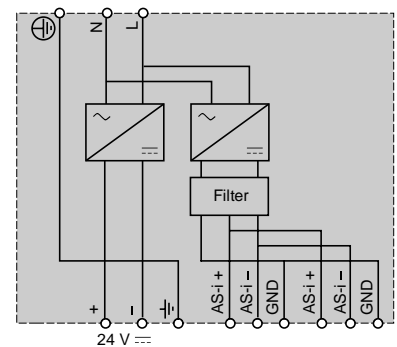

Functions	Supplies for d.c. control circuits
Type of product	Filtered rectified power supplies



Applications	All \sim 24 V circuits. Pilot operation of valves and solenoid valves and double coil contactors.
Nominal power	240...960 W
Input voltage	\sim 380-400-420 V (\pm 10 %) 3-phase.
Output voltage	\sim 24 V
Technology	Filtered rectified power supply.
Protection	External
Signalling	Output indicator lamp.
Other characteristics	Input connectors for regulating undervoltages or overvoltages. Earth screen on all products.
Mounting	Oblong holes
Conforming to standards	IEC 61558-2-6, EN 61558-2-6, DIN 19240, UL 1950, CSA C22.2 N° 950
Approvals	c us
Device type	ABL-6RT●●●●
Pages	26

Transformers for a.c. control circuits

Transformers



Harsh environments.
Supply fluctuating within the range - 10...+ 10 %.
Non-sensitive load: contactors, relays, etc.

24...480 W

~ 215-220-235-385-400-415 V or
~ 105-120-135-225-240-255 V (± 10 %)

≡ 24 V

Single-phase filtered rectified power supply

External or integrated, depending on model

Output indicator lamp.

Input connectors for regulating undervoltages or overvoltages
Earth screen on all products

Oblong holes
Plate for mounting on rail: option for ABL-6RF2401
to ABL-6RF2405

IEC 61558-2-6, EN 61558-2-6, DIN 19240, UL 1950, CSA C22.2 N° 950
c us

ABL-6RF●●●●

26

All control circuits.
Us < 50 V = safety transformer (SELV).
Us > 50 V = isolation transformer

25...2500 VA

~ 230-400 V with + or - 15 V connectors, single-phase

~ 12 V, 24 V, 115 V or 230 V

~ 24-48 V or 115-230 V

Safety and isolation transformers

Single wound secondary

Double wound secondary

External

–

Earth screen on all products

Oblong holes
Plate for mounting on rail: option for ABL-6T●02 to ABL-6T●10

IEC 61558-2-6, EN 61558-2-6, UL 506
c us

ABL-6TS●●●

ABL-6TD●●●

34

Power supplies and transformers

Filtered rectified power supplies for d.c. control circuits

ABL-6R● power supplies

The ABL-6R● range of power supplies is designed to provide the d.c. voltage necessary for the control circuits of automation system equipment. Split into two families, this range meets all the needs encountered in industrial, commercial and residential applications. Single-phase or 3-phase, of the conventional type with rectifier, they provide a quality of output which is suitable for the loads supplied and compatible with the mains supply available in the equipment. Clear guidelines are given on selecting protection devices which are often used with them, and thus a comprehensive solution is provided which can be used in total safety.

Filtered rectified power supplies

Filtered rectified power supplies are built using a safety transformer fitted with a bridge rectifier and smoothing capacitors.

With no regulation system, of simple and rugged construction, their output voltage will withstand mains voltage variations and load variations while remaining within the range defined in standards IEC 1131-2. They are particularly suitable for applications with high current inrush.

These supplies are split into two families:

- The single-phase filtered rectified ABL-6RF family is suitable for connection to European 230/400 V and American 120/240 V single-phase supplies. An optional mounting plate, for mounting on a \sim rail, simplifies their installation.
- The 3-phase filtered rectified ABL-6RT family is particularly suitable where a high power level is required for actuators and preactuators. In particular for "All \sim 24 V" equipment, or for pilot operation of d.c. valves and solenoid valves.

Selection of power supplies

The characteristics to be taken into account when selecting a power supply are:

- the required output voltage and current,
- the mains voltage available in the installation.

An initial selection can be made using the table opposite.

This may however result in several products being selected as suitable.

Other selection criteria must therefore be taken into account.

■ The quality of the mains power supply

Filtered rectified power supplies provide a non-regulated voltage, sensitive to load and mains power supply fluctuations. They can only be used where a good quality mains supply is available, with fluctuations limited to -10 %... + 10 % of the nominal value.

Graphs showing the output voltage as a function of the rated current of the load and the input voltage for ABL-6RF and ABL-6RT supplies are given on page 29.

If the quality of the mains supply is not suitable for a rectified power supply, a regulated supply must be used.

The Phaseo range is the solution because it guarantees precision to 3% of the output voltage, whatever the load current and the input voltage. In addition, the wide input voltage range of Phaseo power supplies allows them to be connected to all mains supplies within this range, without any adjustment.

The Phaseo RP family can also be connected to \sim 110 and 220 V emergency supplies.

■ Harmonic pollution (power factor)

The current drawn by a power supply is not sinusoidal. This leads to the existence of harmonic currents which pollute the mains supply. European standard EN 61000-3-2 limits the harmonic currents produced by power supplies. This standard covers all devices of more than 75 W, drawing up to 16 A per phase and connected directly to the public mains power supply. Devices connected downstream of a private, low voltage general transformer are therefore excluded.

By design, rectified power supplies produce very little harmonic current and can therefore be used on the public mains supply. However, regulated switch mode supplies produce much more harmonic current and a filter circuit (Power Factor Correction or PFC) must therefore be added to comply with standard EN 61000-3-2. ABL-6RF and ABL-6RT power supplies conform to standard EN 61000-3-2 and can therefore be connected directly to public mains power supplies.

■ Behaviour in the event of short-circuits

In the event of an overload or short-circuit, rectified power supplies must be protected by an upstream fuse or circuit-breaker to prevent their destruction. Models ABL-6RF2401, ABL-6RF2402 and ABL-6RF2405 are fitted, as standard, with a 5 x 20 mm glass fuse.



ABL-6RF●●●●



ABL-6RT●●●●

Power supplies and transformers

Filtered rectified power supplies for d.c. control circuits

Selection according to application characteristics			
Rated mains supply voltage	120-240 V ± 15 V 50/60 Hz	230-400 V ± 15 V 50/60 Hz	3x400 V ± 15 V 50/60 Hz
Permissible variation	+/- 10 % 47...63 Hz		
Output voltage	24 V		
Output current	1 A	ABL-6RF2401G2	ABL-6RF2401
	2.5 A	ABL-6RF2402G2	ABL-6RF2402
	5 A	ABL-6RF2405G2	ABL-6RF2405
	10 A		ABL-6RF2410
	15 A		ABL-6RF2415
	20 A		ABL-6RF2420
	30 A		ABL-6RT2430
	40 A		ABL-6RT2440
Conforming to EN 61000-3-2	Yes		Yes
Integrated protection	Yes from 1 to 5 A by fuse No above 5 A		No

Type of power supply			ABL-6RT				ABL-6RF						
			2410	2420	2430	2440	2401●	2402●	2405●	2410	2415	2420	
Technical characteristics													
Input	Input voltages	Permissible values	V	400 3-phase (- 10...+ 10 %) with + 5 % and - 5 % connectors				All products: 230 or 400 single-phase (- 10... +10 %) with - 15 V and + 15 V connectors except ABL-6RF2401●G2: 120 or 240 single-phase (- 10... +10 %) with - 15 V and + 15 V connectors					
		Permissible frequencies	Hz	47...63				47...63					
	Efficiency (1)	%	73	78	77	78	71	75	75	80	80	93	
Output	Precision	Output voltage	V	24 nominal Min: 20.4 - Max: 28.8				24 nominal Min: 20.4 - Max: 28.8					
		Output current	A	10	20	30	40	1	2.5	5	10	15	20
	Residual ripple (1)		≤ 2 %				≤ 5 %						
	Protection	Overload and short-circuit		External, depending on output current				External, depending on output current, except ABL-6RF2401● , ABL-6RF2402● , ABL-6RF2405● : 5 x 20 internal fuse					
		Transient output overvoltage		Peak limiter 2 J				Peak limiter 2 J					
Environment													
Connections	Input	mm ²	1 x 4 + earth										
	Output	mm ²	2 x 4 + earth				2 x 4...2 x 16 + earth						
Ambient air temperature around the device	Storage	°C	- 40...+ 80										
	Operation	°C	- 20...+ 60				- 20...+ 50						
Maximum relative humidity			90 % without condensation or dripping water										
Degree of protection			IP 20										
Protective treatment			"TC"										
Operating position			Any position				Vertical						
Dielectric strength	Input/output	V	~ 4000										
	Input/earth	V	~ 2000										
	Output/earth	V	~ 2000										
Connections	Series		Possible										
	Parallel		Possible, with 20 % derating										
Conforming to standards			IEC 61558-2-6; EN 61558-2-6; UL 1950; IEC 1131-2; CSA-C22.2 N° 950										
Product certifications			c  us										

(1) At nominal input voltage and load

Example using the graph

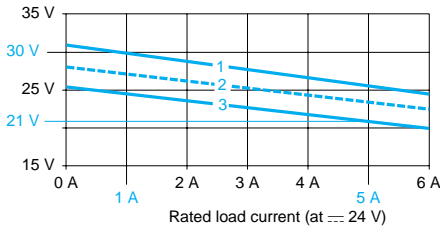

For an ABL-6RF2405 power supply used with a variable load of 1 to 5 A on a mains supply with $U_n \pm 10\%$, the graph shows the limits at the load terminals: 21 and 30 V.

Note: permitted loads are represented vertically as images of the rated load current at rated voltage.

- 1 Rated supply +10%
- 2 Rated supply
- 3 Rated supply -10%

ABL-6RF2401/G2

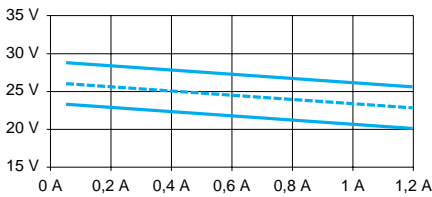

ABL-6RF2405/G2

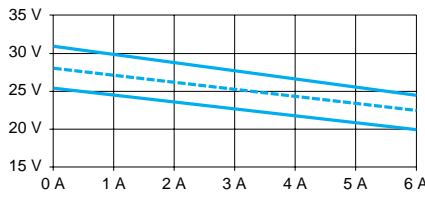

ABL-6RF2410

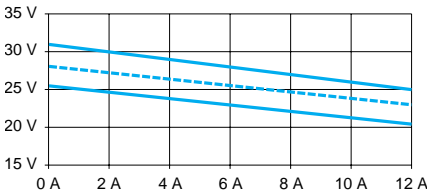

ABL-6RF2415

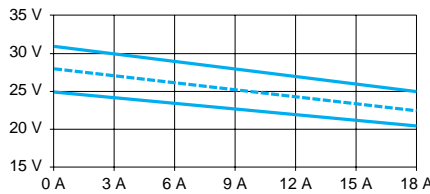

ABL-6RF2420

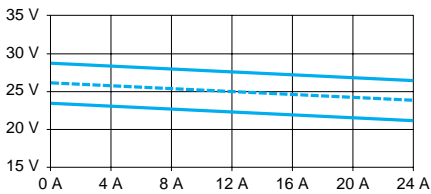

ABL-6RF2410

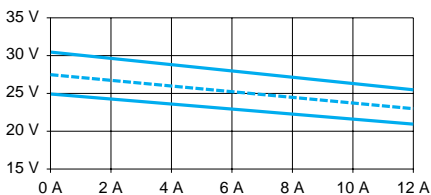

ABL-6RF2410

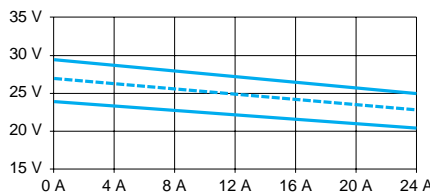

ABL-6RT2430

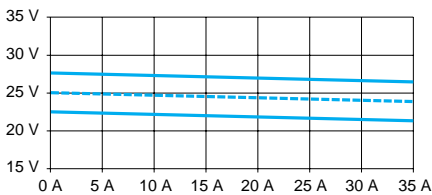

ABL-6RT2440

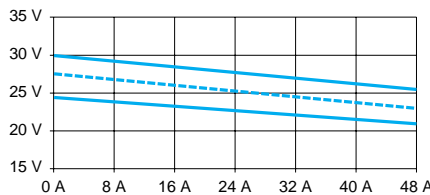

Power supplies and transformers

Filtered rectified power supplies for d.c. control circuits

ABL-6RT power supplies: protection of the power supply line

Type of mains supply	~ 400 V 3-phase				
Type of protection	Thermal-magnetic circuit-breaker 3-pole	Thermal regulation	C60N	FNQ fuse UL listed (1)	aM fuse
ABL-6RF2410	GV2-RT05	0.63 A	MG 24532 (1)	0.5 A T	2 A
ABL-6RF2410	GV2-RT07	1.6 A	MG 24533 (1)	1.125 A T	4 A
ABL-6RT2430	GV2-RT07	2 A	MG 24533 (1)	1.6 A T	4 A
ABL-6RT2440	GV2-RT08	2.6 A	MG 24534 (1)	2.5 A T	4 A

ABL-6RF power supplies: protection of the power supply line

Type of mains supply	~ 230 V single-phase			400 V ~ single-phase					
Type of protection	Thermal-magnetic circuit-breaker		MDL fuse UL listed (1)	aM fuse	Thermal-magnetic circuit-breaker		FNQ fuse UL listed (1)	aM fuse	
	Single-pole	GB2-CB●●	–	–	–	–	–	–	
	2-pole	GB2-DB●●	C60N	–	–	GB2-DB●●	C60N	–	
ABL-6RF2401		GB2-●B05	MG 24516 (1)	0.315 A T	0.5 A	–	MG 24516 (1)	0.15 A T	0.5 A
ABL-6RF2402		GB2-●B06	MG 24516 (1)	0.63 A T	0.5 A	GB2-DB05	MG 24516 (1)	0.3 A T	0.5 A
ABL-6RF2405		GB2-●B07	MG 17453 (1)	1.4 A T	2 A	GB2-DB06	MG 24516 (1)	0.6 A T	1 A
ABL-6RF2410		GB2-●B09	MG 24519 (1)	3.15 A T	4 A	GB2-DB07	MG 17453 (1)	1.25 A T	2 A
ABL-6RF2415		GB2-●B10	MG 17454 (1)	5 A T	6 A	GB2-DB08	MG 24517 (1)	2 A T	4 A
ABL-6RF2420		GB2-●B14	MG 24520 (1)	6 A T	6 A	GB2-DB14	MG 24518 (1)	2.5 A T	6 A

(1) UL certified circuit-breaker

Power supplies and transformers

Filtered rectified power supplies for d.c. control circuits



ABL-6RT●●●●



ABL-6RF●●●●

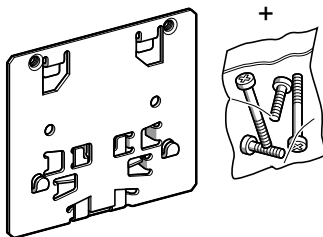

ABL-6AM●● (2)

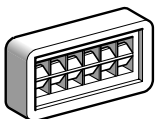

AR1-SB3

3-phase filtered rectified power supplies (1)

Mains input voltage 50/60 Hz	Nominal output voltage	Nominal power	Maximum output current	Reference	Weight
~ V	≡ V	W	A		kg
380-400-420 (±10%) 3-phase	24	240	10	ABL-6RF2410	6.200
		480	20	ABL-6RF2410	10.700
		720	30	ABL-6RT2430	15.150
		960	40	ABL-6RT2440	19.800

Single-phase filtered rectified power supplies (1)

Mains input voltage 50/60 Hz	Nominal output voltage	Nominal power	Maximum output current	Protection by cartridge fuse 5 x 20	Reference	Weight
~ V	≡ V	W	A			kg
215-230-245 (±10%) 385-400-415 (±10%) single-phase	24	24	1	With	ABL-6RF2401 (2)	1.300
		60	2.5	With	ABL-6RF2402 (2)	2.000
		120	5	With	ABL-6RF2405 (2)	3.100
		240	10	Without	ABL-6RF2410	6.100
		360	15	Without	ABL-6RF2415	8.450
105-120-135 (±10%) 225-240-255 (±10%) single-phase	24	24	1	With	ABL-6RF2401G2	1.300
		60	2.5	With	ABL-6RF2402G2	2.000
		120	5	With	ABL-6RF2405G2	3.100

Mounting accessories

Description	For power supplies	Sold in lots of	Unit reference	Weight kg
Plate for mounting (2) on 35 mm Omega or combination rail	ABL-6RF2401●	5	ABL-6AM01	0.050
	ABL-6RF2402●	5	ABL-6AM03	0.065
	ABL-6RF2405●	5	ABL-6AM04	0.085

Marking accessories

Description	Size mm	Sold in lots of	Unit reference	Weight kg
Self-adhesive marker tag holder	20 x 10	50	AR1-SB3	0.010

(1) Separate protection and safety devices: see recommended product references page 30.

(2) It is possible to order a power supply with its corresponding mounting plate. To do this, add the letter **P** to the reference of the selected power supply (example: **ABL-6RF-2401P**).

ABL-6RT24●0

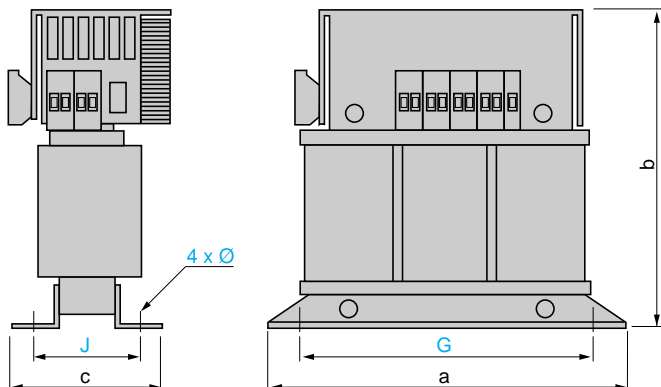

ABL-	a	b	c	G	J	Ø
6RT2410	185	177	100	164	71.5	6.5
6RT2420	220	212	121	196	79.5	8
6RT2430	244	236	130	215	97	8
6RT2440	284	268	143	256.5	105	11

Mounting plates ABL-6AM0●

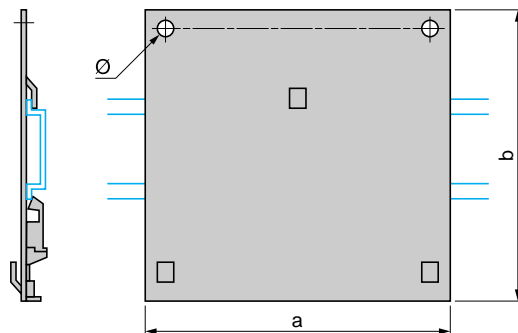

ABL-	a	b	Ø
6AM01	78	70	4
6AM03	84	78	4
6AM04	96	91	5

ABL-6RF24●●

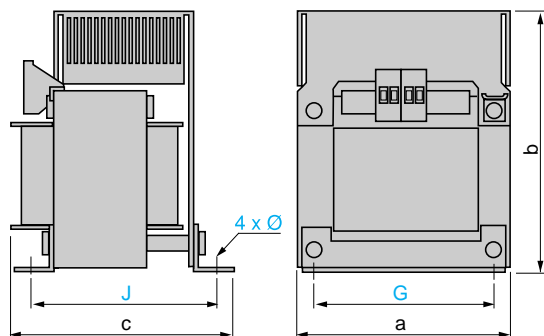

ABL-	a	b	c	G	J	Ø
6RF2401●	78	120	72	56	47.5	4.8
6RF2402●	84	122	87	64	65.5	4.8
6RF2405●	96	132	91	84	75.3	5.8
6RF2410	120	175	119	90	94.5	5.8
6RF2415	135	187	124	104	97	5.8

ABL-6RF2420

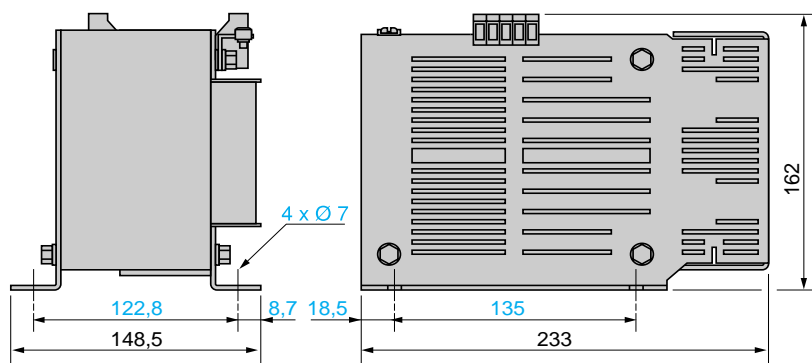

ABL-6RT2400

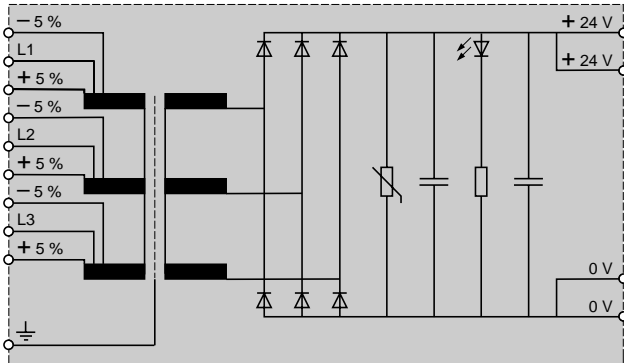

ABL-6RF2401, ABL-6RF2402, ABL-6RF2405

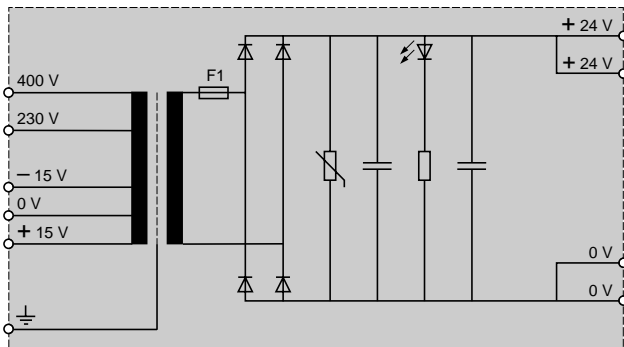

ABL-6RF2410, ABL-6RF2415, ABL-6RF2420

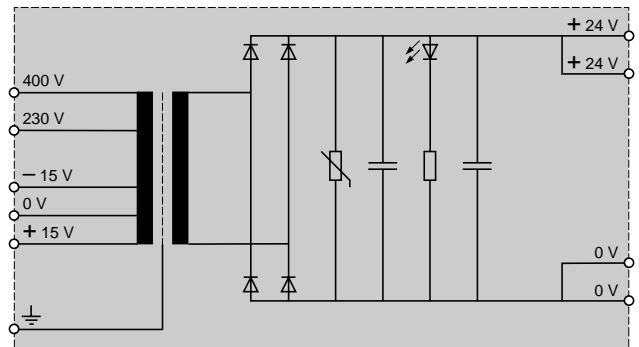

ABL-6RF2401G2, ABL-6RF2402G2, ABL-6RF2405G2

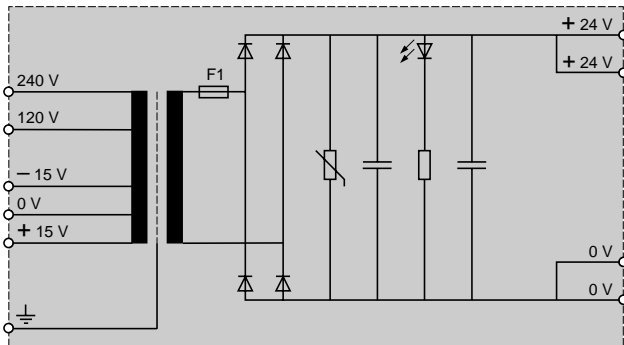

Presentation

The ABL-6T range of single-phase transformers is designed to supply the control circuits of electrical equipment from a 230 or 400 V supply at 50 or 60 Hz. Additional + 15 V and - 15 V connectors can provide better adaptation to the local network if necessary.

ABL-6T transformers ensure reinforced electrical isolation between the supply and application. The entire range is fitted with an earth screen in order to reduce the spreading of electromagnetic interference and increase user safety. ABL-6T transformers are protection class I and are supplied with no housing, degree of protection IP 20.

They conform to IEC 61558-2-6, EN 61558-2-6 standards and are UL certified. They are manufactured to insulation class B or F, depending on the product. The windings are vacuum impregnated with solvent-free resin. The maximum operating temperature is 50 °C without derating.

Connections

The product range makes it possible to cover a power range from 25 to 2500 VA.

All products have a 230/400 V +/- 15 V dual voltage primary and are available in standard versions with voltages for 12, 24, 48, 115 and 230 V control circuits. ABL-6T transformers are available in a single secondary winding version (12, 24, 115 and 230 V) and in a double secondary winding version (2 x 24 or 2 x 115 V) in order to enable series connection (to obtain 48 or 230 V) or parallel connection.

Protection

The transformers can be protected against short-circuits using fuses or thermal-magnetic circuit-breakers mounted on the secondary.

For operation in compliance with UL standards, short-circuit protection must be achieved using fuses (UL approved) mounted on the primary.

Where the control circuit is isolated from the earth (IT scheme), an earth leakage detector will indicate any accidental earth fault (see "Automation and relay functions" catalogue).

Selection

ABL-6T transformers are characterised by the apparent nominal power which they can supply continuously. But they are also designed to supply, when necessary, much higher powers, such as contactor inrush peaks.

Contactor inrush peaks can reach 10 to 20 times the required holding current. This leads to the transformer being oversized in relation to the continuous power it is to supply. The transformer must be sized so that the voltage drop at its terminals, caused by the inrush, remains within the permissible limits for the contactor to close properly.

The two power values which need to be taken into account to determine which transformer rating to use are thus:

- the continuous power which the transformer is to supply
- the maximum inrush current which it must provide.

In practice, only the sum of the holding currents and the largest contactor inrush current need to be considered.

For Telemecanique transformers, the graph below can be used to select the rating to use according to these two currents. This ensures a maximum voltage drop of 5 % at the moment of the inrush, compatible with correct operation of the entire installation. However, these transformers have been designed for continuous operation at nominal load and at an ambient temperature of 50 °C. A reduction in the ambient temperature may uprate the transformer which, in some cases, allows a lower rating to be used.

The graph below has therefore been drawn for 35 and 50 °C.

The inrush values of the contactor coils are given in the contactor control circuit characteristic pages.

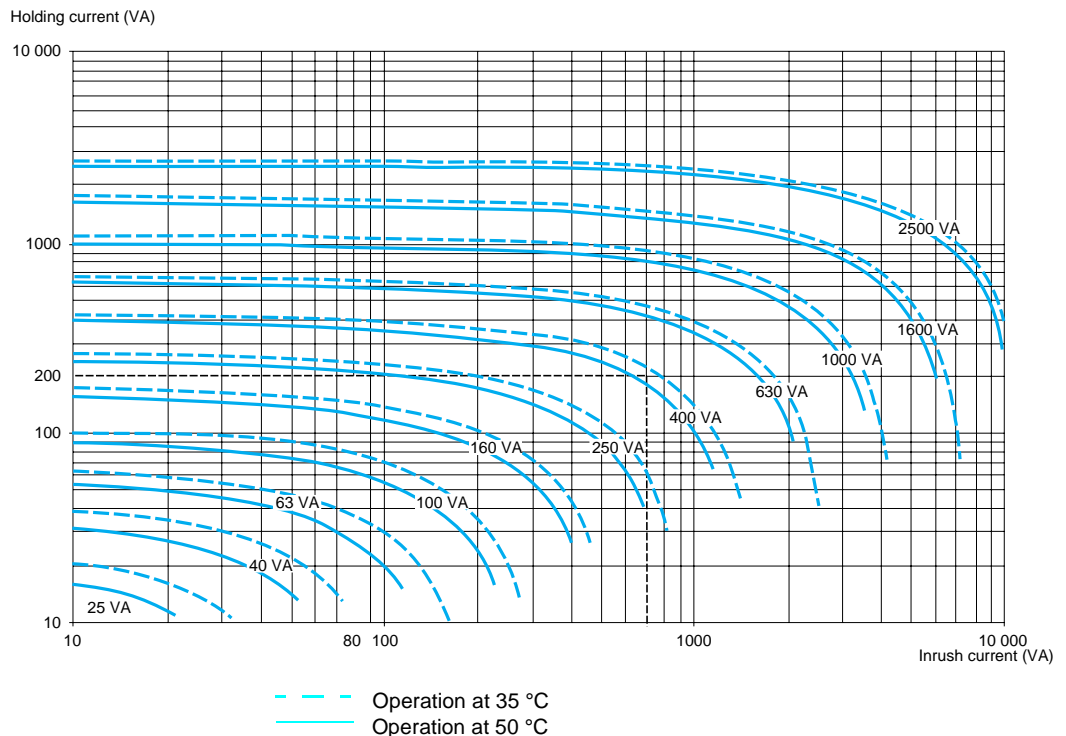

Example: a device with a total holding current of 200 VA and inrush current of the largest contactor of 700 VA can be supplied by a 630 VA transformer if it is used at an ambient temperature of 50 °C. A 400 VA transformer is sufficient if the ambient temperature is 35 °C.

Technical characteristics			
Input voltage	V	230 and 400 single-phase with - 15 V and + 15 V connectors	
Input frequency	Hz	47...63	
Operating and environmental characteristics			
Conforming to standards		IEC-61558-2-6, EN-61558-2-6, UL 506	
Product certifications		UL	
Degree of protection	Conforming to IEC 529	IP 20	
Protective treatment		"TC"	
Dielectric strength	Primary/secondary	V	4000
	Winding/earth	V	2000
Protection class		I	
Insulation		Class F: ABL-6T●160● and ABL-6T●250●, class B: other references	
Ambient air temperature around the device	Storage	°C	- 40...+ 80
	Operation	°C	- 20...+ 50
Operating position		Any	
Mounting	Direct	Elongated holes on all models	
	On  rail	Optional mounting plate for ABL-6T●02●, ABL-6T●04●, ABL-6T●06● and ABL-6T●10●	

Characteristics														
Power	VA	25	40	63	100	160	250	400	630	1000	1600	2500		
Overvoltage no load, hot state	ABL-6TS●●B	%	15	11	9	9	7	6	4	3	3	2	2	
	ABL-6TS●●G	%	15	12	9	8	6	5	4	3	3	2	3	
	ABL-6TS●●J	%	16	14	9	9	7	5	-	-	-	-	-	
	ABL-6TS●●U	%	9	9	9	9	7	5	4	3	3	3	3	
	ABL-6TD●●B	%	4	4	3	4	4	4	4	3	3	2	2	
	ABL-6TD●●G	%	9	9	9	9	7	6	4	3	3	2	3	
Voltage drop at nominal load	ABL-6TS●●B	%	0.3	0.2	0.2	0.0	0.3	0.1	0.7	0.5	- 0.3	0.0	0.5	
	ABL-6TS●●G	%	0	0.4	0.1	0.6	0.7	0.7	0.5	0.3	0.5	0.1	- 0.3	
	ABL-6TS●●J	%	0.6	0	1.3	0.3	0.4	0.6	-	-	-	-	-	
	ABL-6TS●●U	%	5.9	4	1.4	0.6	0.9	0.7	0.7	0.4	5	0	0	
	ABL-6TD●●B	%	10.3	6.1	4.3	3.8	2.9	1.8	0.7	0.6	- 0.2	0.1	0.4	
	ABL-6TD●●G	%	5.9	3.6	0.5	0.2	0.4	0.3	0.4	0.3	0.1	0.3	- 0.3	
Efficiency	ABL-6T●●●●	%	79	81	84	86	88	90	92	93	94	96	96	
No-load losses	ABL-6T●●●●	W	3	4.4	5.3	7.1	9.1	12.5	12.4	18.9	26.5	23.7	23.4	
Short-circuit voltage	ABL-6TS●●B	%	13.52	10.27	8.62	7.86	6.81	5.51	4.50	3.41	2.93	2.50	2.85	
	ABL-6TS●●G	%	14.03	10.71	7.92	7.51	6.65	5.28	4.66	3.47	3.04	2.45	2.61	
	ABL-6TS●●J	%	14.74	12.13	9.63	8	6.9	5.47	-	-	-	-	-	
	ABL-6TS●●U	%	14.34	11.46	9.08	8.32	7.5	5.85	4.77	3.68	3.24	2.65	8.73	
	ABL-6TD●●B	%	13.79	9.32	7.38	7.52	6.46	5.34	4.46	3.46	3.02	2.53	2.73	
	ABL-6TD●●G	%	13.34	11.08	8.30	8.05	7.15	5.63	4.58	3.53	3.16	2.57	2.65	
Connections	Primary	mm ²	4	4	4	4	4	4	4	4	4	4	4	
	Secondary	ABL-6TD●●G	mm ²	4	4	4	4	4	4	4	4	4	4	4
		ABL-6TS●●G	mm ²	4	4	4	4	4	4	4	4	4	10	10
		ABL-6TS●●J	mm ²	4	4	4	4	4	4	-	-	-	-	-
		ABL-6TS●●U	mm ²	4	4	4	4	4	4	4	4	4	4	4
		ABL-6TD●●B	mm ²	4	4	4	4	4	4	4	4	10	10	10
		ABL-6TS●●B	mm ²	4	4	4	4	4	4	10	10	10	16	35

Protection by fuses

Recommended protection for the transformer primary

Transformer Reference	Power	Input voltage ~ 230 V single-phase		Input voltage ~ 400 V single-phase	
		Fuse carrier/isolator		Fuse carrier/isolator	
		MDL fuses UL Listed (1)	aM fuses	FNQ fuses UL Listed (1)	aM fuses
ABL-6T●02●	25 VA	2/10 A	0.5 A	15/100 A	0.5 A
ABL-6T●04●	40 VA	1/4 A	0.5 A	15/100 A	0.5 A
ABL-6T●06●	63 VA	4/10 A	0.5 A	2/10 A	0.5 A
ABL-6T●10●	100 VA	6/10 A	1 A	3/10 A	0.5 A
ABL-6T●16●	160 VA	1 A	2 A	1/2 A	1 A
ABL-6T●25●	250 VA	1 1/2 A	2 A	8/10 A	1 A
ABL-6T●40●	400 VA	2 A	4 A	12/10 A	2 A
ABL-6T●63●	630 VA	3 2/10 A	6 A	2 A	4 A
ABL-6T●100●	1000 VA	5 A	8 A	3 A	6 A
ABL-6T●160●	1600 VA	8 A	10 A	5 A	8 A
ABL-6T●250●	2500 VA	2 A	16 A	7 A	10 A

Recommended protection for the transformer secondary

Transformer Reference	Power	12 V secondary		~ 24 V secondary		~ 48 V secondary		~ 115 V secondary		~ 230 V secondary	
		Fuses gG	T	Fuses gG	T	Fuses gG	T	Fuses gG	T	Fuses gG	T
ABL-6T●02●	25 VA	2 A	2 A	1 A	1 A	0.5 A	0.5 A	–	0.2 A	–	0.1 A
ABL-6T●04●	40 VA	4 A	3.15 A	1 A	1.6 A	0.5 A	0.8 A	–	0.315 A	–	0.16 A
ABL-6T●06●	63 VA	6 A	5 A	2 A	2.5 A	1 A	1.25 A	0.5 A	0.5 A	–	0.25 A
ABL-6T●10●	100 VA	8 A	–	4 A	4 A	2 A	2 A	0.5 A	0.8 A	–	0.4 A
ABL-6T●16●	160 VA	12 A	–	6 A	–	2 A	3.15 A	1 A	1.4 A	0.5 A	0.63 A
ABL-6T●25●	250 VA	20 A	–	10 A	–	4 A	5 A	2 A	2 A	1 A	1 A
ABL-6T●40●	400 VA	–	–	16 A	–	8 A	–	2 A	3.15 A	1 A	1.6 A
ABL-6T●63●	630 VA	–	–	25 A	–	12 A	–	4 A	5 A	2 A	2.5 A
ABL-6T●100●	1000 VA	–	–	40 A	–	20 A	–	8 A	–	4 A	4 A
ABL-6T●160●	1600 VA	–	–	63 A	–	32 A	–	12 A	–	6 A	–
ABL-6T●250●	2500 VA	–	–	100 A	–	50 A	–	20 A	–	10 A	–

Protection by thermal-magnetic circuit-breakers

Recommended protection for the transformer primary

Transformer Reference	Power	Input voltage ~ 230 V single-phase				Input voltage ~ 400 V single-phase			
		Circuit-breaker				Circuit-breaker			
		Telemecanique (2)		Merlin Gerin		Telemecanique		Merlin Gerin	
ABL-6T●02●	25 VA	GB2-●●05	24493	Single-pole	2-pole	GB2-DB05	24494	2-pole	2-pole
ABL-6T●04●	40 VA	GB2-●●05	24493	24493	24494	GB2-DB05	24494	24494	24494
ABL-6T●06●	63 VA	GB2-●●05	24493	24493	24494	GB2-DB05	24494	24494	24494
ABL-6T●10●	100 VA	GB2-●●06	24565	24565	24580	GB2-DB05	24494	24494	24494
ABL-6T●16●	160 VA	GB2-●●07	24566	24566	24581	GB2-DB06	24580	24580	24580
ABL-6T●25●	250 VA	GB2-●●07	24566	24566	24581	GB2-DB06	24580	24580	24580
ABL-6T●40●	400 VA	GB2-●●08	24567	24567	24582	GB2-DB07	24581	24581	24581
ABL-6T●63●	630 VA	GB2-●●10	24568	24568	24583	GB2-DB08	24582	24582	24582
ABL-6T●100●	1000 VA	GB2-●●14	24569	24569	24584	GB2-DB09	24583	24583	24583
ABL-6T●160●	1600 VA	GB2-●●20	–	–	24586	GB2-DB14	24584	24584	24584
ABL-6T●250●	2500 VA	–	–	–	24587	GB2-DB20	24586	24586	24586

Recommended protection for the transformer secondary

Transformer Reference	Power	12 V secondary		~ 24 V secondary		~ 48 V secondary		~ 115 V secondary		~ 230 V secondary	
		Circuit-breaker (2)		Circuit-breaker (2)		Circuit-breaker (2)		Circuit-breaker (2)		Circuit-breaker (2)	
ABL-6T●02●	25 VA	GB2-●●07	24171	GB2-●●06	24170	GB2-●●05	24058	–	–	–	–
ABL-6T●04●	40 VA	GB2-●●09	24173	GB2-●●07	24171	GB2-●●06	24170	–	24058	–	–
ABL-6T●06●	63 VA	GB2-●●10	24174	GB2-●●08	24172	GB2-●●07	24170	GB2-●●05	24059	–	–
ABL-6T●10●	100 VA	GB2-●●14	24175	GB2-●●09	24173	GB2-●●07	24171	GB2-●●06	24170	GB2-●●05	24058
ABL-6T●16●	160 VA	–	24176	GB2-●●12	24174	GB2-●●08	24172	GB2-●●07	24171	GB2-●●06	24059
ABL-6T●25●	250 VA	–	24177	GB2-●●16	24175	GB2-●●10	24174	GB2-●●07	24171	GB2-●●06	24170
ABL-6T●40●	400 VA	–	–	–	24176	GB2-●●14	24175	GB2-●●08	24173	GB2-●●07	24171
ABL-6T●63●	630 VA	–	–	–	24178	GB2-●●20	24176	GB2-●●10	24174	GB2-●●08	24172
ABL-6T●100●	1000 VA	–	–	–	24180	–	24177	GB2-●●14	24175	GB2-●●09	24173
ABL-6T●160●	1600 VA	–	–	–	24182	–	24179	GB2-●●20	24176	GB2-●●12	24174
ABL-6T●250●	2500 VA	–	–	–	–	–	24181	–	24177	GB2-●●16	24175

(1) For operation in compliance with UL.

(2) GB2-CB●●: single-pole, GB2-CD●●: 1 pole protected and 1 pole switched, GB2-DB●●: 2 poles protected.



ABL-6TS●●●

Transformers, dual voltage primary, with earth screen (1)

Primary voltage 50/60 Hz	Secondary	Output voltage	Nominal power	Basic reference to be completed (2)	Usual secondary voltages	Weight
V		V	VA			kg
230/400 ± 15 V single-phase	Single winding	12 (J)	25	ABL-6TS02● (4)	J B G U	0.700
		or	40	ABL-6TS04● (4)	J B G U	1.200
		24 (B)	63	ABL-6TS06● (4)	J B G U	1.600
		or	100	ABL-6TS10● (4)	J B G U	2.100
		115 (G)	160	ABL-6TS16●	J B G U	3.200
		or	250	ABL-6TS25●	J B G U	4.400
		230 (U)	400	ABL-6TS40●	B G U	6.500
			630	ABL-6TS63●	B G U	9.800
			1000	ABL-6TS100●	B G U	14.300
			1600	ABL-6TS160●	B G U	19.400
		2500	ABL-6TS250●	B G U	27.400	
	Double winding (3)	24/48 (B)	25	ABL-6TD02● (4)	B G	0.700
		or	40	ABL-6TD04● (4)	B G	1.200
		115/230 (G)	63	ABL-6TD06● (4)	B G	1.600
			100	ABL-6TD10● (4)	B G	2.100
			160	ABL-6TD16●	B G	3.200
			250	ABL-6TD25●	B G	4.400
			400	ABL-6TD40●	B G	6.500
			630	ABL-6TD63●	B G	9.800
			1000	ABL-6TD100●	B G	14.300
		1600	ABL-6TD160●	B G	19.400	
	2500	ABL-6TD250●	B G	27.400		

Mounting accessories

Description	For transformers	Sold in lots of	Unit reference	Weight kg
Plate for mounting on  rail	ABL-6T●02●	5	ABL-6AM00	0.045
	ABL-6T●04●	5	ABL-6AM01	0.050
	ABL-6T●06●	5	ABL-6AM02	0.055
	ABL-6T●10●	5	ABL-6AM03	0.065

Marking accessory

Description	Size mm	Sold in lots of	Unit reference	Weight kg
Self-adhesive marker tag holder 20 x 10		50	AR1-SB3	0.001

(1) Separate protection and safety devices: see characteristics page 37.

(2) Reference to be completed by adding the code for the secondary voltage.

Secondary voltages available

Volts 50/60 Hz	Single wound secondary				Double wound secondary	
	12	24	115	230	24/48 (3)	115/230 (3)
Item	J	B	G	U	B	G

(3) 48 or 230 V, series connection (see schemes on page opposite)

(4) It is possible to order a power supply with its corresponding mounting plate. To do this, add the letter P to the reference of the selected transformer (example: **ABL-6TS-02BP**).

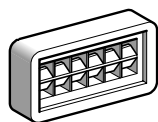

AR1-SB3

Dimensions

Transformers ABL-6T020 to ABL-6T1000

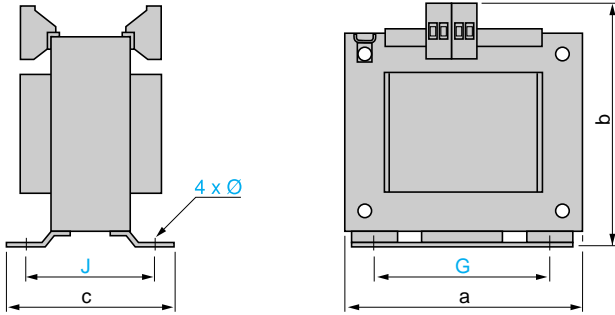

Transformers ABL-6T1600 and ABL-6T2500

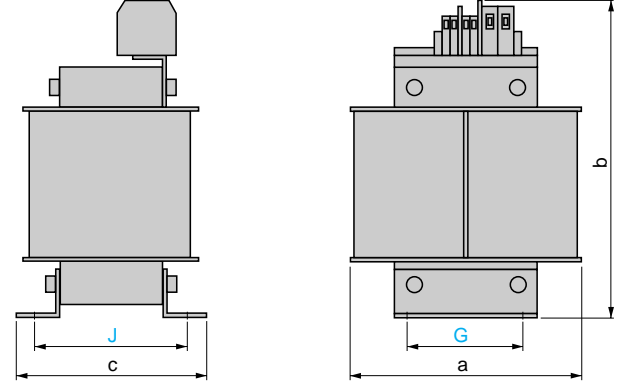

ABL-	a	b	c	G	J	Ø
6T020	66	90	55	55	42	4.8
6T040	78	90	68	56	47.5	4.8
6T060	78	90	80	56	56	4.8
6T100	85	94	86	64	65.5	4.8
6T160	106	109	81	80.5	63	5.8
6T250	120	122	85	90	74.5	5.8
6T400	136	140	120	104	87	5.8
6T630	150	152	138	122	107.5	7
6T1000	174	180	146	135	111.5	7
6T1600	174	221	167	135	138	7
6T2500	198	335	145	125	117	10

Mounting plates ABL-6AM00

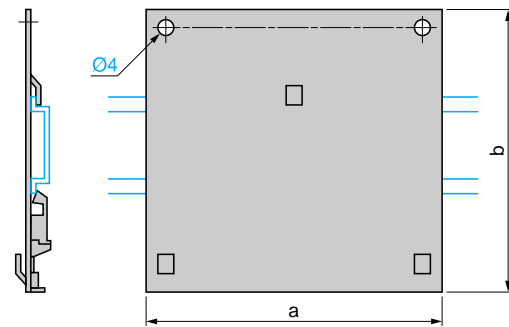

ABL-	a	b
6AM00	68	70
6AM01	78	70
6AM02	78	74
6AM03	84	78

Schemes

ABL-6TS020 to ABL-6TS1600

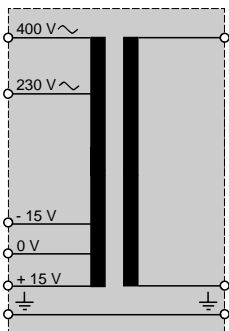

ABL-6TS2500

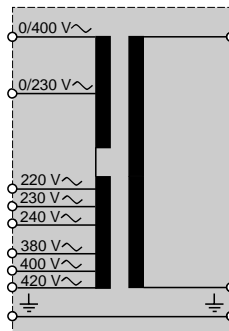

ABL-6TD020 to ABL-6TD1600

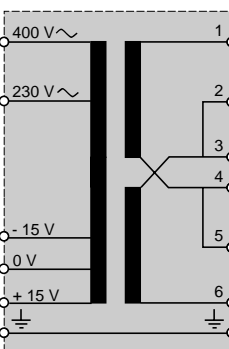

Parallel connection Series connection

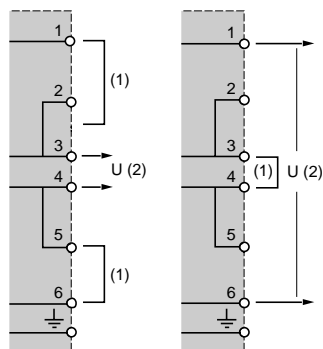

ABL-6TD2500

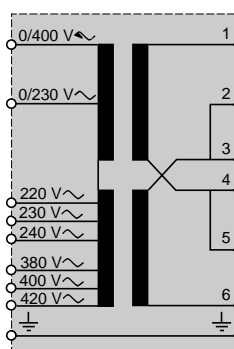

(1) Connection links are supplied with the products. The connection principle is identical for transformers ABL-6TD2500.

(2) Output voltage obtained

Reference	Parallel Connection	Series Connection
ABL-6TD000B	24 V	48 V
6TD000G	115 V	230 V



Schneider Electric worldwide

Up-dated: 28-07-2003

Afghanistan	Contacts are assured by	Schneider Electric India		
Albania	Contacts are assured by	Schneider Electric Austria		
Algeria	■ Schneider Electric	voie A Lot C22 Zone industrielle Rouiba - Alger	Tel. : +213 21 92 97 02 à 09 Fax : +213 21 92 97 00 à 01	
Andorra	Contacts are assured by	Schneider Electric France		
Angola	Contacts are assured by	Schneider Electric South Africa		
Anguilla	Contacts are assured by	Schneider Electric Dominican Rep.		
Antartica	Contacts are assured by	Schneider Electric Brazil		
Antigua & Barbuda	Contacts are assured by	Schneider Electric Dominican Rep.		
Argentina	■ Schneider Argentina	Viamonte 2850 - 1678 Caseros (provincia Buenos Aires)	Tel.: +54 1 716 88 88 Fax: +54 1 716 88 33	www.schneider-electric.com.ar
Armenia	Contacts are assured by	Schneider Electric Russian Fed.		
Aruba	Contacts are assured by	Schneider Electric Dominican Rep.		
Australia	■ Schneider Electric (Australia) Pty. Limited	2 Solent Circuit Norwest Business Park Baulkham Hill _ NSW 2153	Tel.: +61 298 51 28 00 Fax: +61 296 29 83 40	www.schneider.com.au
Austria	■ Schneider Austria Ges.m.b.H.	Birostrasse 11 1239 Wien	Tel.: +431 610 540 Fax: +431 610 54 54	www.schneider-electric.at
Azerbaijan	Contacts are assured by	Schneider Electric Russian Fed.		
Bahamas	■ Schneider Electric	Union Village PO Box 3901 - Nassau	Tel. : +1 242 327 42 91 Fax : +1 242 327 42 91	www.squared.com
Bahrain	■ Schneider Electric	Floor 1 - Juma Building Abu Horaira Avenue PO Box 355 - 304 Manama	Tel.: +97 322 7897 Fax: +97 321 8313	
Bangladesh	Contacts are assured by	Schneider Electric India		
Barbados	Contacts are assured by	Schneider Electric Dominican Rep.		
Belarus	■ Schneider Electric Industries SA	Prospect Macherova 5, of. 202 220004 Minsk	Tel. : +375 172 23 75 50 Fax : +375 172 23 97 61	
Belgium	■ Schneider Electric nv/sa	Dieweg 3 B - 1180 Brussels	Tel.: +3223737711 Fax: +3223753858	www.schneider-electric.be
Belize	Contacts are assured by	Schneider Electric USA		
Benin	Contacts are assured by	Schneider Electric Ivory Coast		
Bermuda	Contacts are assured by	Schneider Electric Dominican Rep.		
Bhutan	Contacts are assured by	Schneider Electric India		
Bolivia	Contacts are assured by	Schneider Electric Chile		
Bosnia and Herzegovina	Contacts are assured by	Schneider Electric Croatia		
Botswana	Contacts are assured by	Schneider Electric South Africa		
Bouvet island	Contacts are assured by	Schneider Electric Dominican Rep.		
Brazil	■ Schneider Electric Brazil Ltda.	Avenida Das Nações Unidas 23223 Jurubatuba - CEP 04795-907 São Paulo-SP	Tel.: +55 55 24 52 33 Fax: +55 55 22 51 34	www.schneider-electric.com.br
Brunei (Darussalam)	Contacts are assured by	Schneider Electric Singapore		
Bulgaria	■ Schneider Electric	Expo 2000, Boulevard Vaptzarov 1407 Sofiav	Tel.: +3592 919 42 Fax: +3592 962 44 39	www.schneiderelectric.bg
Burkina Faso	Contacts are assured by	Schneider Electric Ivory Coast		
Burundi	Contacts are assured by	Schneider Electric Kenya		
Cambodia	Contacts are assured by	Schneider Electric Viet Nam		
Cameroon	■ Schneider Electric Cameroon	166, rue de l'Hôtel de Ville BP12087 - Douala	Tel.: +237 343 38 84 Fax: +237 343 11 94	
Canada	■ Schneider Canada	19, Waterman Avenue M4 B1Y2 Toronto - Ontario	Tel.: +1 416 752 8020 Fax: +1 416 752 4203	www.schneider-electric.ca
Cape Verde	Contacts are assured by	Schneider Electric Senegal		
Caribee	Contacts are assured by	Schneider Electric Dominican Rep.		
Cayman islands	Contacts are assured by	Schneider Electric Dominican Rep.		
Central African Republic	Contacts are assured by	Schneider Electric Cameroon		
Chad	Contacts are assured by	Schneider Electric Cameroon		
Chile	■ Schneider Electric Chile S.A.	Avda. Pde Ed. Frei Montalva, 6001-31 Conchali - Santiago	Tel.: +56 2 444 3000 Fax: +56 2 423 9335	www.schneider-electric.co.cl
China	■ Schneider Beijing	Landmark bldg-Room 1801 8 North Dong Sanhuan Rd Chaoyang District 100004 Beijing	Tel.: +86 10 65 90 69 07 Fax: +86 10 65 90 00 13	www.schneider-electric.com.cn



Schneider Electric worldwide

Up-dated: 28-07-2003

Christmas island	Contacts are assured by	Schneider Electric Australia	
Cocos (Keeling) islands	Contacts are assured by	Schneider Electric Australia	
Colombia	■ Schneider Electric de Colombia S.A.	Calle 45A #102-48 Bogota DC	Tel.: +57 1 426 97 00 Fax: +57 1 426 97 40
Comoros	Contacts are assured by	Schneider Electric la Reunion	
Congo	Contacts are assured by	Schneider Electric Cameroon	
Cook islands	Contacts are assured by	Schneider Electric Australia	
Costa Rica	■ Schneider Centroamérica Ltda.	1.5 kms oeste de la Embajada Americana, Pavas, San José, Costa Rica C.A. Apartado: 4123-1000 San Jose	Tel.: +506 232-60-55 Fax: +506 232-04-26 www.schneider-ca.com
Croatia	■ Schneider Electric SA	Fallerovo Setaliste 22 HR - 10000 Zagreb	Tel.: +385 1 367 100 Fax: +385 1 367 111
Cuba	■ Schneider Electric	Bureau de Liaison de La Havane Calle 36- N°306-Apto1 Entre 3ra y 5ta Avenida Miramar Playa Habana	Tel.: +53 724 15 59 Fax: +53 724 12 17
Cyprus	■ Schneider Electric Cyprus	28 General Timayia Avenue Kyriakos Building, Block #A301 Larnaca 6046	Tel.: +00357 248 12646 Fax: +00357 246 37382
Czech Republic	■ Schneider Electric CZ, s.r.o.	Thámova 13 Praha 8 - 186 00	Tel.: +420 2 810 88 111 Fax: +420 2 24 81 08 49 www.schneider-electric.cz
Democratic Rep. of Congo	Contacts are assured by	Schneider Electric Cameroon	
Denmark	■ Schneider Electric A/S	Baltorpbakken 14 DK-2750 Ballerup	Tel.: +45 44 73 78 88 Fax: +45 44 68 5255 www.schneider-electric.dk
Djibouti	Contacts are assured by	Schneider Electric Egypt	
Dominican Republic	■ Schneider Electric	Calle Jacinto Manon Esq. Federico Geraldino Edificio D' Roca Plaza Suite 402, Ens. Paraiso - Santo Domingo	Tel.: +1 809 334 66 63 Fax: +1 809 334 66 68
Ecuador	■ Schneider Electric Ecuador SA	Av. Republica del Salvador 1082 y Nac Edificio Mansion Blanca-Quito	Tel. : +593 2 224 42 42 Fax : +593 2 224 42 94
Egypt	■ Schneider Electric Egypt sae	68, El Tayaran Street Nasr City, 11371 - Cairo	Tel.: +20 24 01 01 19 Fax: +20 24 01 66 87 www.schneider.com.eg
El Salvador	Contacts are assured by	Schneider Electric USA	
Equatorial Guinea	Contacts are assured by	Schneider Electric Cameroon	
Eritrea	Contacts are assured by	Schneider Electric Egypt	
Estonia	■ Lexel Electric	Ehitajate tee 110 EE 12618 Tallinn	Tel. : +372 650 97 00 Fax : +372 650 97 22
Ethiopia	Contacts are assured by	Schneider Electric Egypt	
Falkland islands	Contacts are assured by	Schneider Electric Brazil	
Faroe islands	Contacts are assured by	Schneider Electric Australia	
Fiji	Contacts are assured by	Schneider Electric Australia	
Finland	■ Schneider Electric Oy	Sinimäentie 14 02630 Espoo	Tel. : +358 9 527 000 Fax : +358 9 5270 0376 www.schneider-electric.fi
France	■ Schneider Electric SA	5, rue Nadar 92500 Rueil Malmaison	Tel.: +33 (0)1 41 29 82 00 Fax: +33 (0)1 47 51 80 20 www.schneider-electric.fr
French Polynesia	Contacts are assured by	Schneider Electric Australia	
French West Indies	Contacts are assured by	Schneider Electric Dominican Rep.	
Gabon	Contacts are assured by	Schneider Electric Cameroon	
Gambia	Contacts are assured by	Schneider Electric Senegal	
Georgia	Contacts are assured by	Schneider Electric Russian Fed.	
Germany	■ Schneider Electric GmbH	Gothaer Straße 29 D-40880 Ratingen	Tel.: +49210 240 40 Fax: +492 10 240 49 256 www.schneiderelectric.de
Ghana	■ Schneider Electric Ghana	PMB Kia 3rd Floor Opeibea House Airport Commercial Center Liberation road - Accra	Tel. : +233 21 70 11 687 Fax : +233 21 77 96 22
Gibraltar	Contacts are assured by	Schneider Electric Spain	
Greece	■ Schneider Electric AE	14th km - RN Athens-Lamia GR - 14564 Kifissia	Tel.: +302 106 29 52 00 Fax: +302 106 29 52 10 www.schneider-electric.com.gr
Greenland	Contacts are assured by	Schneider Electric United States	
Grenada	Contacts are assured by	Schneider Electric Dominican Rep.	
Guadeloupe	Contacts are assured by	Schneider Electric Martinique	
Guam	Contacts are assured by	Schneider Electric Australia	



Schneider Electric worldwide

Up-dated: 28-07-2003

Guatemala	Contacts are assured by	Schneider Electric United States	
Guinea-Bissau	Contacts are assured by	Schneider Electric Sénégal	
Guinea	Contacts are assured by	Schneider Electric Ivory Coast	
Guyana	Contacts are assured by	Schneider Electric United States	
Haiti	Contacts are assured by	Schneider Electric Dominican Rep.	
Heard & Mac Donald isl.	Contacts are assured by	Schneider Electric Australia	
Honduras	Contacts are assured by	Schneider Electric United States	
Hong Kong	■ Schneider Electric (Hong Kong) Ltd	Room 3108-28, 31th Floor, Sun Hung Kai Centre, 30 Harbour Road, Wanchai	Tel.: +852 25 65 06 21 Fax: +852 28 11 10 29
Hungary	■ Schneider Electric Hungária Villamossági Rt.	Fehérvári út 108 – 112 H-1116 Budapest	Tel.: +36 1 382 26-06 Fax: +36 1 206 1429
Iceland	Contacts are assured by	Schneider Electric Denmark	
India	■ Schneider Electric India	Max House, 1 Dr Jha Marg, Okhla 110 020 New Dehli	Tel. : +91 11 631 85 84 Tel. : +91 11 631 71 61
Indonesia	■ P.T. Schneider Indonesia	Ventura Building 7th Floor Jalan R.A. Kartini Kav.26 Cilandak - 12430 Jakarta	Tel.: +62 +21 750 44 06 Fax: +62 +21 750 44 15/ 16
Iran (Islamic Republic of)	■ Telemecanique Iran	1047 Avenue VALI ASSR P.O. Box 15875-3547 15116 Teheran	Tel.: +98 218 71 01 42 Fax: +98 218 71 81 87
Irak	■ Schneider Electric Industries SA	38050 Grenoble Cedex 9	Tel.: +33 04 76 60 54 27 Fax: +33 04 76 60 56 60
Ireland	■ Schneider Electric Ireland	Maynooth Road Cellbridge - Co. Kildare	Tel.: +353+0 1 6012200 Fax: +353+0 1 6012201
Italy	■ Schneider Electric S.p.A.	Centro Direzionale Colleoni Palazzo Sirio - Viale Colleoni, 7 20041 Agrate Brianza (Mi)	Tel.: +39 39 655 8111 Fax: +39 39 605 6237
Ivory Coast	■ Schneider Electric Afrique de l'Ouest	Rue Pierre et Marie Curie 18 BP 2027 Abidjan 18	Tel.: +225 21 75 00 10 Fax: +225 21 75 00 30
Jamaica	■ Schneider Electric	Shop#5, Plaza Dunrobin 30 Dunrobin Avenue - Kingstown	Tel. : +1876 755 41 27 Tel. : +931 87 74
Japan	■ Schneider Electric Japan Ltd	Torigoe F. Bldg 1-8-2, Torigoe Taito-Ku - 111-0054 Tokyo	Tel.: +81 358 35 35 81 Fax: +81 358 35 35 85
Jordan	■ Schneider Electric Industr. Jordan	Jordan University Street Abu Al Haj Commercial Complex 2nd Floor - Office # 202 - Amman	Tel.: 962 65 16 78 87 Fax: 962 65 16 79 1
Kazakstan	■ Schneider Electric Kazakhstan Liaison Office	Prospekt Abaia 157 off 9 480009 Almaty	Tel. : +7 327 250 93 88 Tel. : +7 327 250 63 70
Kenya	■ Schneider East Africa	Power Technics Complex Monbasa Road - PO Box 46345 Nairobi	Tel. : +254 2.824.156 Fax : +254 2.824.157
Kiribati	Contacts are assured by	Schneider Electric Australia	
Korea	■ Schneider Electric Korea Ltd	3Floor, Cheil Bldg., 94-46, 7-Ka Youngdeungpodong, Youngdeungpo-ku 150-037 Seoul	Tel. : +82 2 2630 9700 Fax : +82 2 2630 9800
Kurdistan	Contacts are assured by	Schneider Electric Russian Fed.	
Kuwait	■ Schneider Electric Kuwait	Al Gaas Tower - Sharq 2nd Floor PO Box 20092 - 13 061 Safat	Tel.: +965 240 75 46 Fax: +965 240 75 06
Kyrgyz Republic	Contacts are assured by	Schneider Electric Russian Fed.	
Laos	Contacts are assured by	Schneider Electric Thailand	
Latvia	■ Lexel Electric	60A A.Deglava str. LV1035 Riga	Tel. : +371 780 23 74/75 Fax : +371 754 62 80
Lebanon	■ Schneider Electric Liban	Tabaris, Avenue Charles Malek Immeuble Ashada, 8 P.O. Box 166223 - Beyrouth	Tel. : +961 1 20 46 20 Tel. : +961 1 20 31 19
Lesotho	Contacts are assured by	Schneider Electric South Africa	
Liberia	Contacts are assured by	Schneider Electric Ghana	
Libya	Contacts are assured by	Schneider Electric Tunisia	
Liechtenstein	Contacts are assured by	Schneider Electric Switzerland	
Lithuania	■ Lexel Electric	44, Verkiu str. LT-2012 Vilnius	Tel. : +370 278 59 59/61 Fax : +370 278 59 60
Loro Sae	Contacts are assured by	Schneider Electric Australia	
Luxembourg	■ Schneider Electric Industrie SAS	Agence de Metz 1, Rue Graham Bell - BP n° 35190 57075 Metz cedex 3 - France	Tel.: 33 03 87 39 06 03 Fax: 33 03 87 74 25 96



Schneider Electric worldwide

Up-dated: 28-07-2003

Macau	Contacts are assured by	Schneider Electric China		
Macedonia	Contacts are assured by	Schneider Electric Bulgaria		
Madagascar	Contacts are assured by	Schneider Electric la Reunion		
Malawi	Contacts are assured by	Schneider Electric South Africa		
Malaysia	■ Schneider Electric (Malaysia) Sdn Bhd	No.11 Jalan U1/19, Seksyen U1 Hicom-Glenmarie Industrial Park 40150 Shah Alam Selangor Darul Ehsan	Tel.: (603) 7883 6333 Fax: (603) 7883 6188	www.schneider-electric.com.my
Maldives	Contacts are assured by	Schneider Electric Reunion		
Mali	Contacts are assured by	Schneider Electric Senegal		
Malta	Contacts are assured by	Schneider Electric Tunisia		
Marshall islands	Contacts are assured by	Schneider Electric Australia		
Martinique	■ Schneider Electric	Schneider Electric Immeuble Cottrell - ZI de la Lézarde 97232 Le Lamentin	Tel.: +05 96 51 06 00 Fax: +05 96 51 11 26	
Mauritania	Contacts are assured by	Schneider Electric Senegal		
Mauritius	■ Schneider Electric	Route côtière Calodyne - Mauritius	Tel.: 230 282 18 83 Fax: 230 282 18 84	
Mayotte	Contacts are assured by	Schneider Electric Reunion		
Mexico	■ Groupe Schneider Mexico	Calz. Rojo Gomez N° 1121-A Col. Guadalupe del Moral México, D.F. - C.P. 09300	Tel.: +525 686 30 00 Fax: +525 686 24 09	www.schneider-electric.com.mx
Micronesia	Contacts are assured by	Schneider Electric Australia		
Moldova	Contacts are assured by	Schneider Electric Romania		
Monaco	Contacts are assured by	Schneider Electric France		
Mongolia	Contacts are assured by	Schneider Electric Russian Fed.		
Montserrat	Contacts are assured by	Schneider Electric Dominican Rep.		
Morocco	■ Schneider Electric Morocco	26, rue Ibnou Khalikane Quartier Palmiers 20100 Casablanca	Tel.: +212 299 08 48 to 57 Fax: +212 299 08 67 and 69	www.schneider.co.ma
Mozambique	Contacts are assured by	Schneider Electric South Africa		
Myanmar	Contacts are assured by	Schneider Electric Singapore		
Namibia	Contacts are assured by	Schneider Electric South Africa		
Nauru	Contacts are assured by	Schneider Electric Australia		
Nepal	Contacts are assured by	Schneider Electric India		
Netherlands	■ Schneider Electric BV	Waarderweg 40 - Postbus 836 2003 RV Haarlem	Tel.: +31 23 512 4124 Fax: +31 23 512 4100	www.schneider-electric.nl
Netherlands Antilles	Contacts are assured by	Schneider Electric Dominican Rep.		
New Caledonia	Contacts are assured by	Schneider Electric Australia		
New Zealand	■ Schneider Electric (NZ) Ltd	14 Charann Place Avondale P.O. Box 15355 - New Lynn Auckland	Tel.: +64 9 829 04 90 Fax: +64 9 829 04 91	www.schneider-electric.co.nz
Nicaragua	Contacts are assured by	Schneider Electric United States		
Niger	Contacts are assured by	Schneider Electric Ivory Coast		
Nigeria	■ Schneider Electric Nigeria Limited	Biro plaza - 8th Floor - Plot 634 Abeyemo Alakija Street Victoria Islan - Lagos	Tel.: +234 1 2702973 Fax: +234 1 2702976	
Niue	Contacts are assured by	Schneider Electric Australia		
Norfolk island	Contacts are assured by	Schneider Electric Australia		
North Korea	Contacts are assured by	Schneider Electric China		
Northern Mariana islands	Contacts are assured by	Schneider Electric Australia		
Norway	■ Schneider Electric Norge A/S	Solgaard Skog 2 Postboks 128 - 1501 Moss	Tel.: +47 6924 9700 Fax: +47 6925 7871	www.schneider-electric.no
Oman	■ Schneider Electric CA	c/o Arab Development Co PO Box 439 - 113 Muscat	Tel.: +968 77 163 64 Fax: +968 77 104 49	
Pakistan	■ Schneider Electric Pakistan	43-L, 2nd floor, M.M. Alam Road, Gulberg II - Lahore	Tel.: +92 42 5754471 à 73 Fax: +92 42 5754474	
Palau	Contacts are assured by	Schneider Electric Australia		
Panama	Contacts are assured by	Schneider Electric United States		
Papua New Guinea	Contacts are assured by	Schneider Electric Australia		
Paraguay	Contacts are assured by	Schneider Electric Uruguay		



Schneider Electric worldwide

Up-dated: 28-07-2003

Peru	■ Schneider Electric Peru S.A.	Los Telares n°231 Urb. Vulcano, Ate Lima 03	Tel.: +511 348 44 11 Fax: +511 348 05 23	www.schneider-electric.com.pe
Philippines	■ Schneider Electric Philippines, Inc	5th Floor, ALCO Building 391 Sen. Gil Puyat Avenue Makati 1209	Tel. : +632 896 6063 Fax : +632 896 7229	
Pitcairn	Contacts are assured by	Schneider Electric Australia		
Poland	■ Schneider Electric Polska Sp.zo.o.	ul. Lubinowa 4a 03-878 - Warszawa	Tel.: +48 22 511 8 200 Fax: +48 22 511 8 210	www.schneider-electric.pl
Portugal	■ Schneider Electric Portugal	Av.do Forte, 3 Edificio Suécia II, Piso 3-A CP 2028 Carnaxide 2795 Linda-A-Velha	Tel.: +351 21 416 5800 Fax: +351 21 416 5857	www.schneiderelectric.pt
Puerto Rico	Contacts are assured by	Schneider Electric United States		
Qatar	■ Schneider Electric Qatar Branch	c/o Khalifa BinFahred Al Thani Trad.and Co - P.O. Box 4484 Doha	Tel.: +97 4424358 Fax: +97 4424358	
Reunion	■ Schneider Electric	Immeuble Futura, 190, rue des 2 canons BP 646 - 97497 Sainte Clothilde	Tel.: +262 28 14 28 Fax: +262 28 39 37	
Romania	■ Schneider Electric	Bd Ficusului n°42 Apimondia, Corp.A, et.1, Sector 1 Bucuresti	Tel.: +401 203 06 50 Fax: +401 232 15 98	www.schneider-electric.ro
Russian Federation	■ Schneider Electric ZAO	Enisseyskaya 37 129 281 Moscow	Tel.: +7095 797 40 00 Fax: +7095 797 40 03	www.schneider-electric.ru
Rwanda	Contacts are assured by	Schneider Electric Kenya		
Samoa	Contacts are assured by	Schneider Electric Australia		
San Marino	Contacts are assured by	Schneider Electric Italy		
Sandwich & Georgia island	Contacts are assured by	Schneider Electric Australia		
Sao Tome & Principe	Contacts are assured by	Schneider Electric Senegal		
Saudi Arabia	■ Schneider Electric	Second Industrial City P.O. Box 89249 - 11682 Riyadh	Tel.: +966 1 265 1515 Fax: +966 1 265 1860	
Senegal	■ Schneider Electric Sénégal	BP 15952 - Dakar-Fann Rond point N'Gor - Dakar	Tel.: +221 820 68 05 Fax: +221 820 58 50	
Seychelles	Contacts are assured by	Schneider Electric Reunion		
Sierra Leone	Contacts are assured by	Schneider Electric Ghana		
Singapore	■ Schneider Electric Singapore Pte Ltd	10 Ang Mo Kio Street 65 #02-17/20 TechPoint Singapore 569059	Tel.: +65 484 78 77 Fax: +65 484 78 00	www.schneider-electric.com.sg
Slovak Republic	■ Schneider Electric Slovakia spol s.r.o.	Borekova 10 SK-821 06 Bratislava	Tel. : +02 45 52 40 10 and 40 30 Fax : +02 45 52 40 00	www.schneider-electric.sk
Slovenia	■ Schneider Electric, d.o.o.	Dunasjka 47 1000 Ljubljana	Tel. : +386 1 23 63 555 Fax : +386 1 23 63 559	www.schneider-electric.si
Solomon islands	Contacts are assured by	Schneider Electric Australia		
Somalia	Contacts are assured by	Schneider Electric Egypt		
South Africa	■ Schneider Electric South Africa (PTY) Ltd	Private Bag X139 Halfway House 1685 - Midrand.	Tel.: +27 11 254 6400 Fax: +27 11 315 8830	www.schneider-electric.co.za
Spain	■ Schneider Electric España, S.A.	Pl. Dr. Letamendi, 5-7 08007 Barcelona	Tel.: +34 93 484 3100 Fax: +34 93 484 3308	www.schneiderelectric.es
Sri Lanka	■ Schneider Electric Industries SA	Liaison office SRI Lanka Level 3B Valiant towers 46/7 Nawam Mawatha-Colombo 2	Tel. : +94 77 48 54 89	www.schneiderelectric-in.com
St Helena	Contacts are assured by	Schneider Electric Italy		
St Kitts & Nevis	Contacts are assured by	Schneider Electric Dominican Rep.		
St Lucia	Contacts are assured by	Schneider Electric Dominican Rep.		
St Pierre et Miquelon	Contacts are assured by	Schneider Electric Dominican Rep.		
St Vincent & Grenadines	Contacts are assured by	Schneider Electric Dominican Rep.		
Sudan	Contacts are assured by	Schneider Electric Egypt		
Suriname	Contacts are assured by	Schneider Electric United States		
Svalbard & Jan Mayen isl.	Contacts are assured by	Schneider Electric Denmark		
Swaziland	Contacts are assured by	Schneider Electric South Africa		
Sweden	■ Schneider Electric AB	Djupdalsvägen 17/19 19129 Sollentuna	Tel.: +46 8 623 84 00 Fax: +46 8 623 84 85	www.schneider-electric.se
Switzerland	■ Schneider Electric (Switzerland) S.A.	Schermenwaldstrasse 11 CH - 3063 Ittigen	Tel.: +41 31 917 3333 Fax: +41 31 917 3355	www.schneider-electric.ch



Schneider Electric worldwide

Up-dated: 28-07-2003

Syrian Arab Republic	■ Schneider Electric Syria	Elba Street - Malki Gheibeh and Qassas bldg, 1st floor PO Box 33876-Damascus	Tel. : +963 11 37 49 88 00 Fax : +963 11 37 17 55 9	
Taiwan, Republic of China	■ Schneider Electric Taiwan Co Ltd	2Fl., N°37, Ji-Hu Road, Nei-Hu Dist., Taipei 114	Tel. : +886 2 8751 6388 Fax : +886 2 8751 6389	www.schneider-electric.com.tw
Tajikistan	Contacts are assured by	Schneider Electric Russian Fed.		
Tanzania, United Rep. of	Contacts are assured by	Schneider Electric Kenya		
Thailand	■ Schneider (Thailand) Ltd	20th Floor Richmond Building 75 Sukhumvit 26 Road, Klongtoey Bangkok 10110	Tel.: +662 204 9888 Fax: +662 204 9816	www.schneider-electric.co.th
Togo	Contacts are assured by	Schneider Electric Ivory Coast		
Tokelau	Contacts are assured by	Schneider Electric Australia		
Tonga	Contacts are assured by	Schneider Electric Australia		
Trinidad & Tobago	■ Schneider Electric	6, 1st Street West Ext. Beaulieu Avenue Trincity Trinidad West Indies	Tel.: 1868 640 42 04 Fax: 1868 640 42 04	
Tunisia	■ Schneider Electric Tunisia	Rue du Lac Oubeira 1053 Les Berges du Lac - Tunis	Tel.: +216 71 960 477 Fax: +216 71 960 342	
Turkey	■ Schneider Elektrik Sanayi Ve Ticaret A.S.	Tütüncü Mehmet Efendi Cad. N°:110 Kat 1-2 - 81080 Göztepe – Istanbul	Tel.: +90 21 63 86 95 70 Fax: +90 21 63 86 38 75	www.schneiderelectric.com.tr
Turkmenistan	■ Schneider Electric Turkmenistan Liaison Office	rue Neitralny Turkmenistan 28, off.326/327 74 000 Achgabad	Tel. : +993 12 46 29 52 Fax : +993 12 46 29 52	
Turks & Caicos islands	Contacts are assured by	Schneider Electric Dominican Rep.		
Tuvalu	Contacts are assured by	Schneider Electric Australia		
Uganda	Contacts are assured by	Schneider Electric Kenya		
Ukraine	■ Schneider Electric	Rue Krechtchalik 2 252601 Kiev	Tel.: +380 44 462 04 25 Fax: +380 44 462 04 24	www.schneider-electric.com.ua
United Arab Emirates	■ Schneider Electric Abu Dhabi	PO Box 29580 Office Floor 2/Lulu Street Al Marina Plaza Tower Abu Dhabi	Tel.: +9712 6 339444 Fax: +9712 6 316606	
United Kingdom	■ Schneider Electric Ltd	Braywick House East Windsor Road - Maidenhead Berkshire SL6 1 DN	Tel.: +44 (0)1 628 508 500 Fax: +44 (0)1 628 508 508	www.schneider.co.uk
United States	■ Schneider Electric	North American Division 1415 Roselle Road Palatine - IL 60067	Tel.: +1 847 397 2600 Fax: +1 847 925 7500	www.squared.com
Uruguay	■ Schneider Electric Uruguay S.A.	Ramon Masini 3190 Montevideo	Tel. : +59 82 707 2392 Fax : +59 82 707 2184	
Uzbekistan	Contacts are assured by	Schneider Electric Russian Fed.		
Vanuatu	Contacts are assured by	Schneider Electric Australia		
Vatican city St./Holy See	Contacts are assured by	Schneider Electric Italy		
Venezuela	■ Schneider Mg SD TE, S.A	Calle 162/ Piso 2 Edificio Centro Cynamid La Urbina, 1070 - 75319 Caracas	Tel.: +58 2 241 13 44 Fax: +58 2 243 60 09	www.schneider-electric.com.ve
Viet Nam	■ R.R.O. of Schneider Electric Industries S.A.S. in Viet Nam	Unit 2.9, 2nd Floor, e-Town Building 364 Cong Hoa Street Tan Binh District - Ho Chi Minh City	Tel.: +84 8 8103 103 Fax: +84 8 8120 477	
Virgin islands	Contacts are assured by	Schneider Electric Dominican Rep.		
Wallis & Futuna islands	Contacts are assured by	Schneider Electric Australia		
Western Sahara	Contacts are assured by	Schneider Electric Morocco		
Yemen	Contacts are assured by	Schneider Electric U.A.E.		
Yugoslavia	■ Schneider Electric Jugoslavija d.o.o.	Ratarski put 27d 11186 Belgrade	Tel.: +381 11 192 414 Fax: +381 11 107 125	
Zambia	■ Schneider Zambia	Zambia Office c/o Matipi Craft Center Building Plot 1036 - Accra Road PO Box 22792 - Kitwe	Tel.: +260 222 22 52 Fax: +260 222 83 89	
Zimbabwe	■ Schneider Electric	Zimbabwe Liaison Office 75A Second Street (corner Livingstone Avenue) Harare	Tel.: +263 4 707 179/180 Fax: +263 4 707 176	

Schneider Electric Industries SAS

Headquarters

89, bd Franklin Roosevelt
F - 92506 Rueil Malmaison Cedex

<http://www.schneider-electric.com>

Owing to changes in standards and equipment, the characteristics given in the text and images in this document are not binding until they have been confirmed with us.

Production : Schneider Electric Industries
Photos : Schneider Electric Industries
Printed by :

